

Using a 32-bit motor driver chip and Field-Oriented Control (FOC), the RoboMaster CR20 Brushless DC Motor Speed Controller enables precise control over motor torque.



ROBOMASTER

Exclusively designed for the RoboMaster M3508 P19 Brushless DC Gear Motor and CR20 Brushless DC Motor Speed Controller, this M3508 Accessories Kit includes several cables and a terminal board.

Refer to System Specification Manual, RoboMaster User Manual, Introduction of Release System Module

the M3508 Accessories Kit includes several cables and a terminal board. Refer to the System Specification Manual for details.

ROBOMASTER 2019

ROBOTICS COMPETITION

REFEREE SYSTEM SPECIFICATION MANUAL

Prepared by the RoboMaster Organizing Committee
Updated on April, 2019

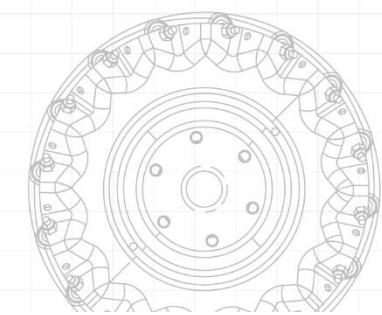
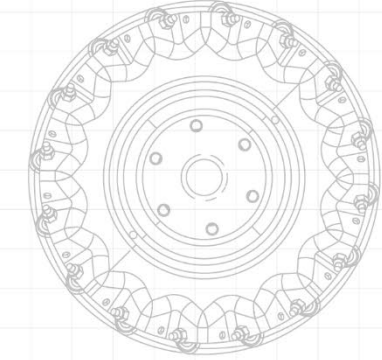
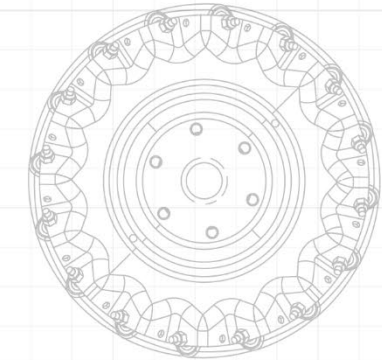
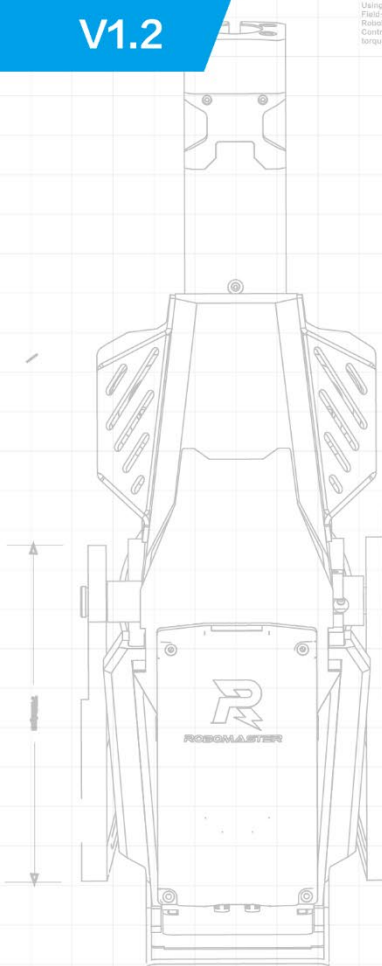
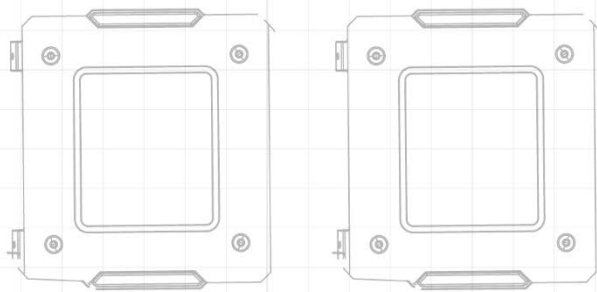

Disclaimer

Please read this disclaimer carefully before using this product. By using this product, you hereby signify that you have read and agreed to all content herein. Please install and use this product properly and in strict accordance with the User Manual and product instructions, as well as any relevant laws, regulations, and policies. Users shall be responsible for the consequences resulting from their behavior while using this product. DJI™ Innovations (DJI™) shall not be liable for any losses incurred from using, installing, or modifying this product improperly.

DJI™ and RoboMaster™ are trademarks of SZ DJI Technology Co., Ltd and its affiliates. Names of products, brands, etc. herein are trademarks or registered trademarks of their respective owner companies. This product, the manual, and the software and driver that work with the Referee System (RoboMaster Client, RoboMaster Server, RoboMaster Tools, RoboMaster Tool 2, and DJI WIN driver) are copyrighted by DJI with all rights reserved, and shall not be modified, reproduced, or transmitted in any form without the prior consent of DJI. DJI reserves the right of final interpretation of this disclaimer.

Product Usage Precautions

1. Please ensure that the Referee System's robot side is installed correctly and firmly before use.
2. Please ensure that the wiring connection between each module on the Referee System's robot side is correct before use.
3. Please ensure that the components are intact before use. Replace any worn or damaged components.

Using This Manual

Legend



Important



Hints and Tips

Related Documents

1. Referee System User Manual
2. Referee System Modules Instruction

It is recommended to read the aforementioned Modules Instruction to understand the features and installation methods of each Referee System module. Reserve any necessary installation holes and spaces so that each module on the Referee System's robot side may be correctly installed, and then read the User Manual to explore the features of the Referee System.

Release Notes





Date	Version	Changes
2018.9.30	V1.0	Release
2018.12.18	V1.1	<ol style="list-style-type: none"> 1. Update dimensions and annotation of some 2D diagrams 2. Update install reference of Main Controller Module 3. Update instructions of NO.6 and NO.7 interfaces of Power Management Module and parameters of power output interface 4. Update shield area definition and install suggestion of top Armor Module 5. Update install specification of Positioning System Module of Sentry and Aerial
2019.4.30	V1.2	<ol style="list-style-type: none"> 1. Update the Wi-Fi signal protection area in the Installation Specification of Main Controller Module 2. Add the emphasis of fixing Armor Module Support Frame A 3. Update the angle value of the lower edge of the Side Armor Module of Standard and Hero 4. Add suggestion of adding a bumper to protect the Armor Module 5. Update installation image of the Positioning System Module and rectify the 145° annotation in the figure 6. Add requirement of the light bar shielding area on both sides of the Speed Monitor Module

Date	Version	Changes
		7. Add two fixing schemes of 17 mm Speed Monitor Module

Contents

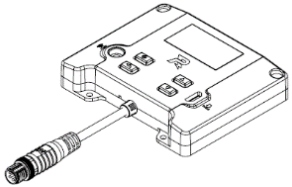
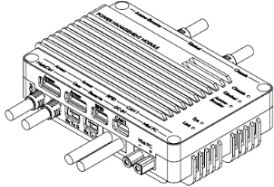
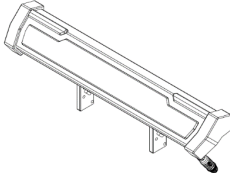
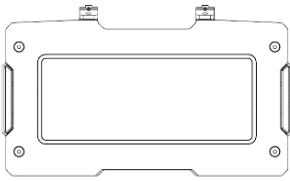
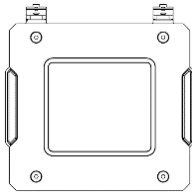
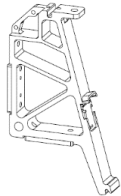
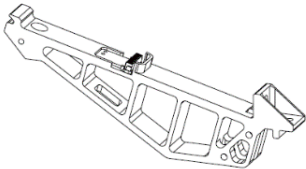
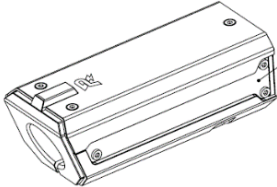
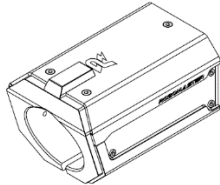
Disclaimer	2
Product Usage Precautions	2
Using This Manual	2
Legend	2
Related Documents	2
Release Notes	3
1. In the Box	6
2. Referee System Usage Specification	8
2.1 Configuration of Referee System	8
2.2 Module Installation Specification	8
2.2.1 Main Controller Module	8
2.2.2 Power Management Module	11
2.2.3 Light Indicator Module	15
2.2.4 Armor Module	18
2.2.5 Speed Monitor Module	29
2.2.6 RFID Interaction Module	36
2.2.7 Video Transmission Module	38
2.2.8 Positioning System Module	40
3. Competition Geo-Fence	43
3.1.1 Purpose	43
3.1.2 Principle Introduction	43
Appendix 17mm Speed Monitor Module Adapter Block Engineering Drawing	45

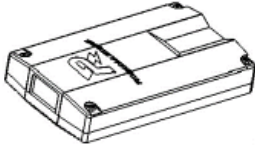
1. In the Box

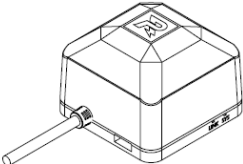
Main Controller Module MC02	Power Management Module PM01	Light Indicator Module LI01
		
Armor Module (Large) AM12	Armor Module (Small) AM02	Armor Module Support Frame A
		
Armor Module Support Frame B	Speed Monitor Module (17 mm Projectile) SM01	Speed Monitor Module (42 mm Projectile) SM11
		
RFID Interaction Module FI02	RFID Interaction Module Card	Video Transmission Module (Transmitter) VT02
		
Video Transmission Module (Receiver) VT12	Positioning System Module	-
		-



The product code for each module will not be stated again later in the document. For example, the Main Controller Module MC02 will be directly referred to as the Main Controller Module.

2. Referee System Usage Specification

In order to ensure the fairness and justness of the RoboMaster 2019 Robotics Competition, the robot's battle results are automatically evaluated by the electronic referee system. Each team must follow the instructions stated in the Usage Specification and correctly install the referee system. In case of any violations, the team shall bear the consequences of failing the pre-match inspection.

2.1 Configuration of Referee System

Type \ Qty.	Main Controller	Power Management	Light Indicator	Large Armor	Small Armor	VTM (Transmitter)	RFID Interaction	Speed Monitor (17 mm Projectile)	Speed Monitor (42 mm Projectile)	Positioning System
Standard	1	1	1	1	4	1	1	1	0	1
Sentry	1	1	1	2	0	0	0	1	0	1
Hero	1	1	1	5	0	1	1	1	1	1
Aerial	1	1	0	0	0	1	0	1	0	1
Engineer	1	1	1	0	4	1	1	0	0	1

2.2 Module Installation Specification



The dimension unit of parts in this manual is mm.

The Referee System is provided by the RoboMaster Organizing Committee. It records a robot's status, such as the robot's HP, projectile launching speed, and chassis power consumption. The Referee System sends status updates to the Operator Room and Referee System Server to automatically determine the result of each round and ensure the fairness of the competition. Teams must reserve the mechanical and electrical interfaces for installing the various modules of the Referee System on their robots.

2.2.1 Main Controller Module

Standard, Hero, Engineer, Sentry and Aerial:

Refer to dimensions of the Main Controller Module as shown below and reserve mounting holes in specified positions on the robot.

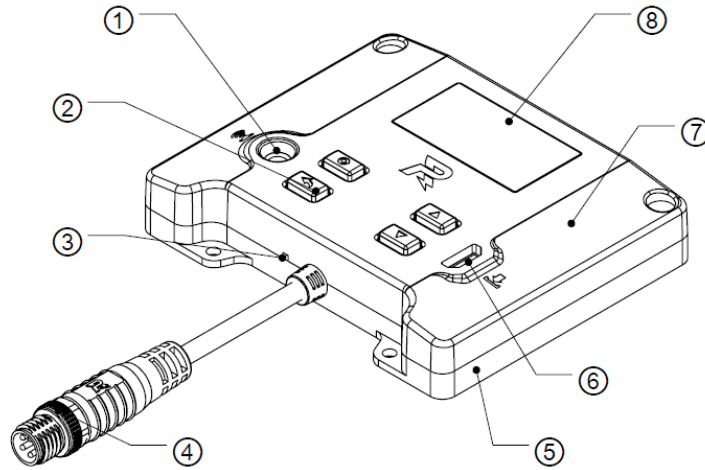

- | | | | |
|--------------------|---------------------|----------------------|---------------------------------------|
| ① IR Receiver | ② Button | ③ Power Indicator | ④ Black Metal Ring Aviation Connector |
| ⑤ Lower Metal Case | ⑥ Upgrade Interface | ⑦ Upper Plastic Case | ⑧ Screen |

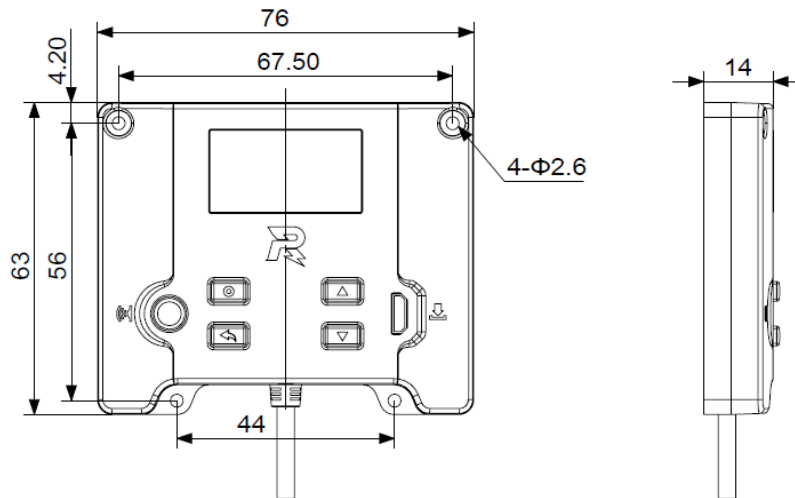

Installation Procedure of Main Controller Module

1. Use four M2.5 screws to mount the Main Controller Module to the specified position on the robot, and ensure that the upper surface of the Main Controller Module is level and faces up when the robot is operating.



The parts that are not included In the Box can be customized and installed on the back of the Armor Module by using M3 threaded holes that are reserved for the Armor Support Frame. Robots must have non-metal shields on four sides to prevent projectiles.

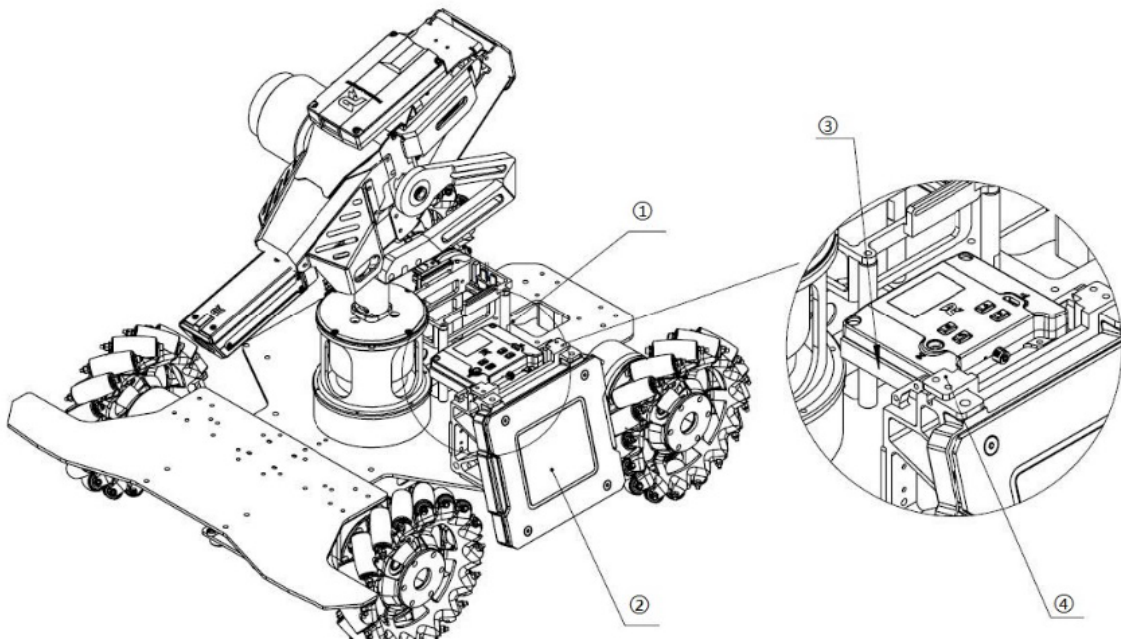

① Main Controller Module ② Armor Module

③ Protective Shield ④ Customized Parts

2. Use the aviation connector cable inside the package to connect the Main Controller Module to the aviation connector with the black metal ring on the Power Management Module as shown.

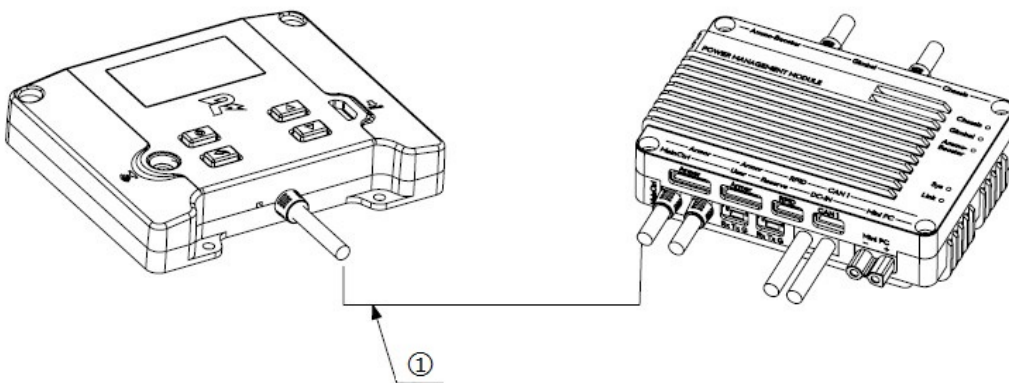

① Aviation Connector Cable

Installation Requirement of Main Controller Module

The installation of the Main Controller Module must meet the following requirements:

- The interactive surface (screen and button) has no metal shield within 50 mm above it and can be protected with foams that are easy to lift up, so that users can interact easily.
- The logo is at the center and there are no motors or other devices with electromagnetic interference within a hemisphere of 70 mm to prevent the Wi-Fi signal from being blocked.

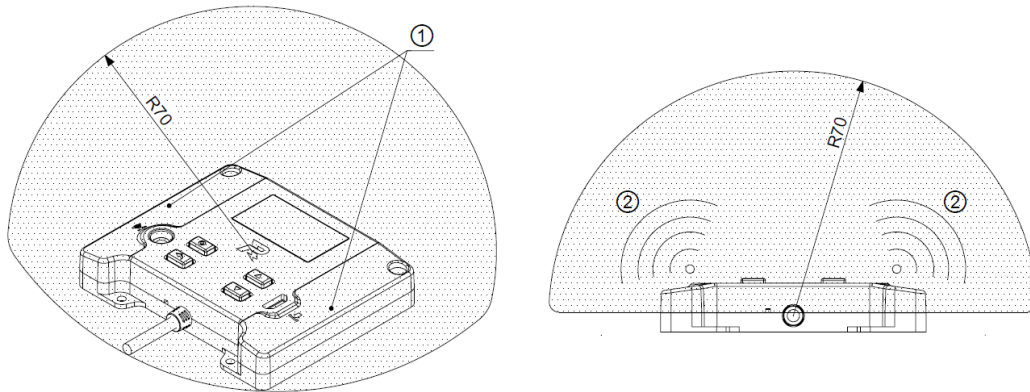

① Antenna Position ② Signal Direction

- The infrared receiver is not blocked, which is easy for users to manually connect to the Server during the competition.
- The installation position of the Main Controller Module should be easy for users to press button and check information on the screen and to plug the cable into the upgrade interface for firmware upgrade.

2.2.2 Power Management Module

Standard, Hero, Engineer, Sentry and Aerial:

Refer to dimensions of the Power Management Module as shown below and reserve mounting holes in specified positions on the robot.

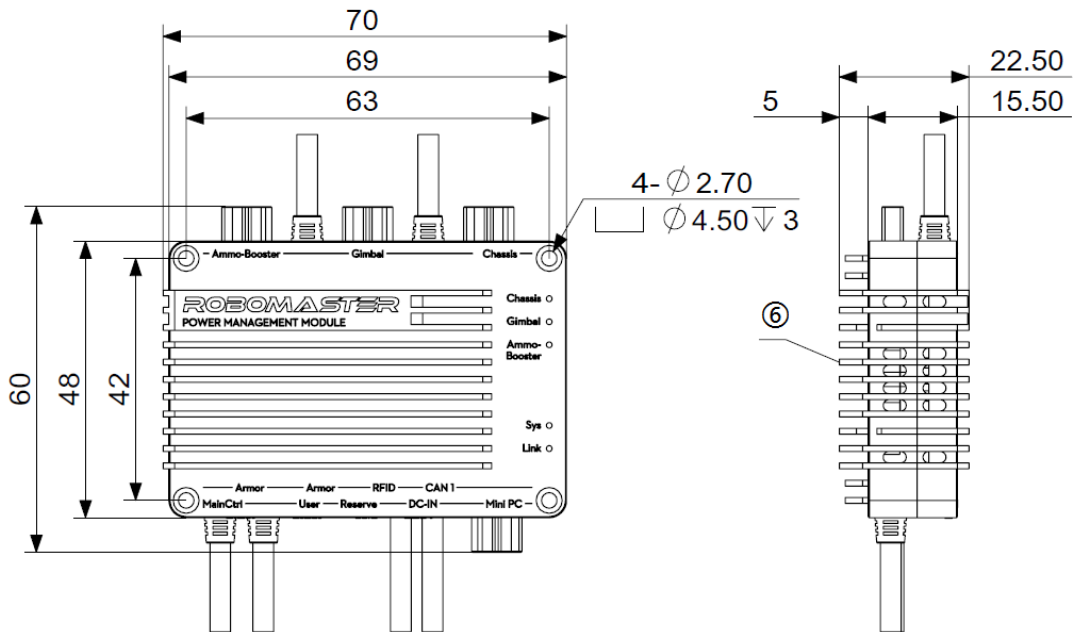
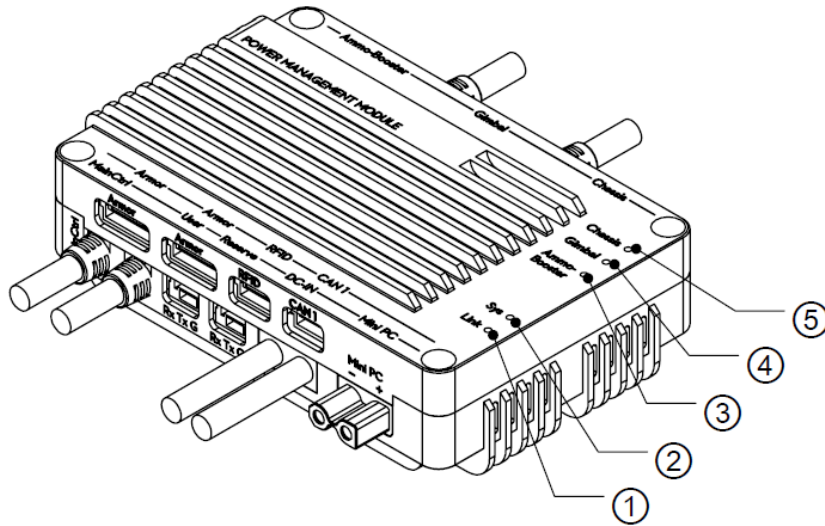

- ① Connection Status Indicator
- ② System Status Indicator
- ③ Launching Mechanism Power Output Indicator
- ④ Gimbal Power Output Indicator
- ⑤ Chassis Power Output Indicator
- ⑥ Bottom Installation Surface

Installation Procedure of Power Management Module

1. Use four M2.5 screws to mount the Power Management Module to the robot.

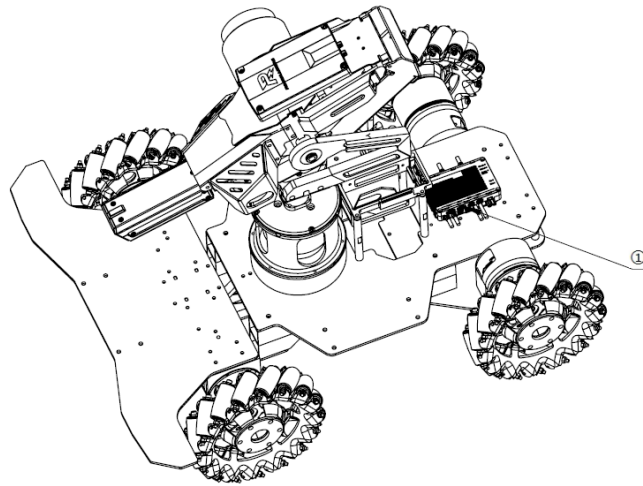

① Power Management Module

- Carefully distinguish the interfaces of the Power Management Module to ensure correct cabling.

The chassis power of all ground robots must be directly connected to the Chassis Interface on the Power Management Module. The gimbal power supply must be connected to the Gimbal Interface on the Power Management Module. The Launching Mechanism power of Aerial must be connected to the Ammo-Booster Interface on the Power Management Module. For robots without power limitation, the chassis, or gimbal power supply, has a maximum continuous current of more than 10A and can be directly powered by the robot's battery and controlled by a relay. The relay must be powered by the corresponding interface to ensure that when the robot is defeated, the Referee System can power on or off all devices connected to the Referee System Power Interface (Output), otherwise it is considered cheating.

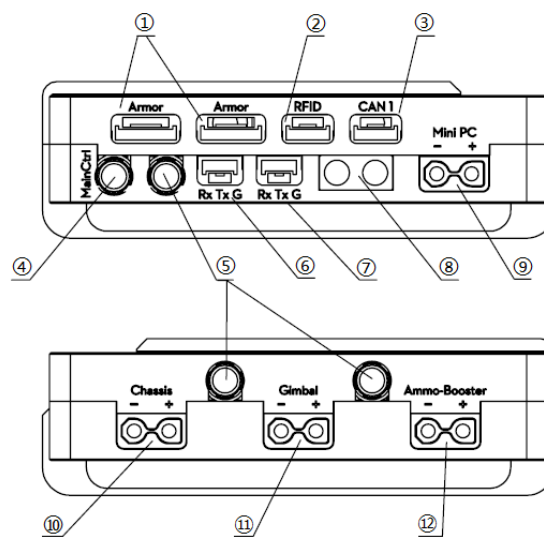

① Armor Module SM06B-GHS-TB ② RFID Interaction Module SM04B-GHS-TB

Interface	Interface
③ CAN Communication SMO4B-GHS-TB Interface	④ Main Controller Module Interface (the metal ring of the aviation connector is black)
⑤ Interface for the rest of the Referee System Module (Speed Monitor, UWB, VTM or Light Indicator; the metal ring of the aviation connector is silver)	
⑥ User SMO3B-GHS-TB Interface	⑦ System Upgrade SMO3B-GHS-TB Interface
⑧ Referee System Power Supply XT60 Interface (Input)	⑨ Mini PC Power Supply XT30 Interface (Output)
⑩ Referee System Power Supply XT30 Interface (Output) - connect to the chassis	
⑪ Referee System Power Supply XT30 Interface (Output) - connect to the gimbal	
⑫ Referee System Power Supply XT30 Interface (Output) - connect to the Launching Mechanism	

Installation Requirement of Power Management Module

The installation of the Power Management Module must meet the following requirements:

- The status indicator is not blocked.
- Each socket of the Power Management Module should be shielded from projectiles while the outer case should not be completely covered to ensure good heat dissipation.



- Power Management Module input voltage requirement: 22 V-26 V. No.10, No.11 and No.12 power output interfaces shown above can be powered on and off by the Referee System. The maximum continuous load of No.10 and No.11 interfaces is 10 A. The peak value is 30 A and it lasts a maximum duration of 500 ms. For No.12 interface, the maximum continuous load is 8 A, the peak value is 20 A and it lasts a maximum duration of 500 ms. The total continuous load for No.10, No.11 and No.12 interfaces is 20 A. The No.9 output interface has a maximum continuous load of 6 A.
- For Power Management Modules with a 10-12 power output interface, if the single load reaches the hardware limit, it will trigger the power module's overload protection, which will turn off the output, so pay attention to the reasonable distribution of the load when designing the circuit.
- Pay attention to No.9 to No.12 output interfaces and frequent plugging will result in loose interfaces.
- When the system load fluctuates greatly, the voltage of No.9 to No.12 output interfaces will also fluctuate. It is recommended that voltage-balancing methods are applied to the load like Mini PC that is sensitive to voltage.
- The case of the Power Management Module becomes hot under the condition of high power. DO NOT touch it. The Power Management Module should not be installed on non-heat-resistant materials such as 3D printed materials. DO NOT fix the Power Management Module with glue materials like 3D tape.



Test result: With a current of 20 A and working time of 30 minutes, the case temperature will be about 70°C.

2.2.3 Light Indicator Module

Standard, Hero, Engineer and Sentry:

Refer to dimensions of the Light Indicator Module as shown below and it is mounted on the robot via a mounting bracket.

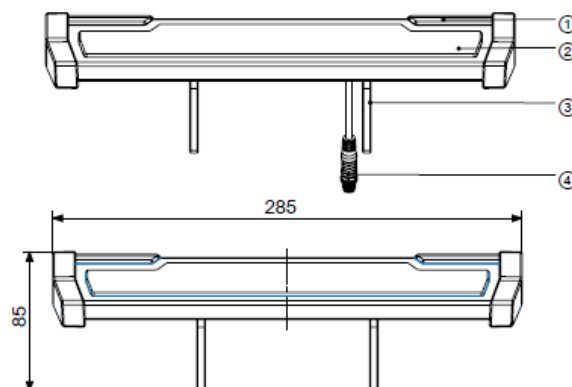

- ① Auxiliary Light Indicator ② Main Light Indicator

③ Mounting Bracket

④ Aviation Connector

Installation Procedure of Light Indicator Module

1. The Light Indicator module can be mounted on the Armor Module. Use ten M3 screws to mount the Light Indicator Module to the Armor Module Support Frame.

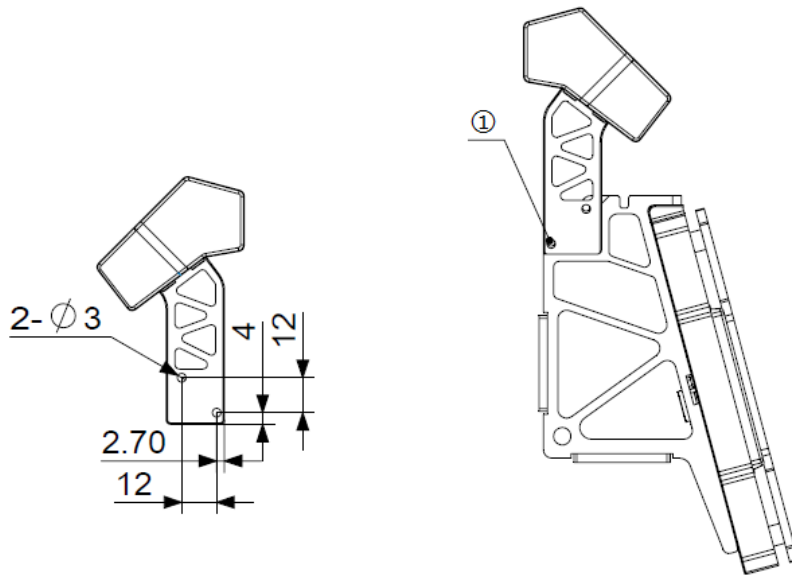

① Screw Mounting Position

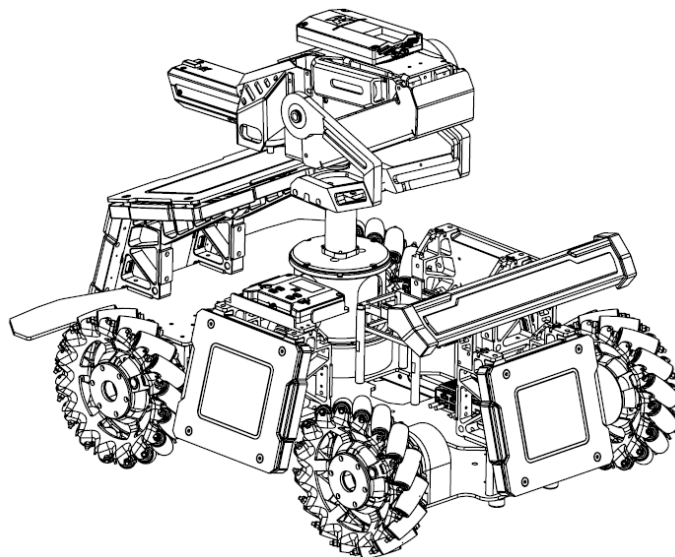

2. Optional: The Light Indicator Module can be fixed to the bottom screw hole of the mounting bracket and mounted on a suitable position on the robot.

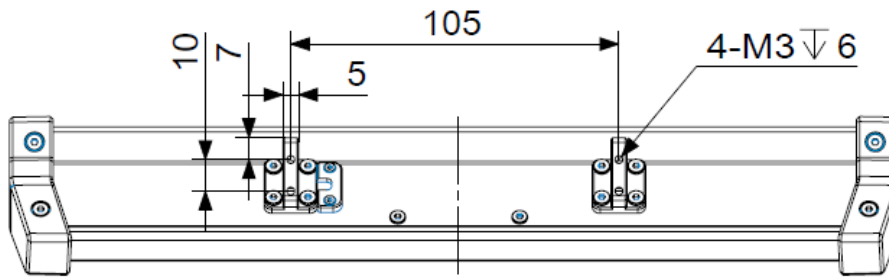

- Use the aviation connector cable inside the package to connect the Light Indicator Module to the aviation connector with the white metal ring on the Power Management Module.

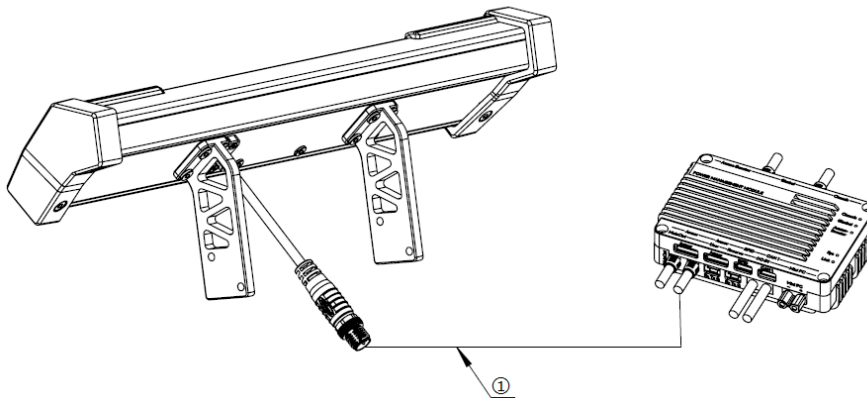

① Aviation Connector Cable

Installation Requirement of Light Indicator Module

The installation of the Light Indicator Module must meet the following requirements:

- The line drawn between the left and right auxiliary Light Indicators is parallel to the ground.
- The main Light Indicator and the auxiliary Light Indicators must be completely visible when looking at the robot from at least one horizontal direction.



When installing the Light Indicator Module of Standard, the position of the main Light Indicator must be higher than the upper edge of the Armor Module.

Sentry:

The mounting position of the Light Indicator Module on Sentry is different. Use the mounting bracket of the Light Indicator Module to mount to Sentry through the mounting holes on the side or the screw holes on the bottom.

Sentry is mounted onto the Rail. Ensure that the Light Indicator Module is on one side of the Rail and the illuminated part (the main Light Indicator and the auxiliary Light Indicator) is above the upper surface of

the Rail. All Referee System modules count toward the overall size constraints except the Light Indicator Module, the Positioning System Module and the Positioning System Module Support Frame.

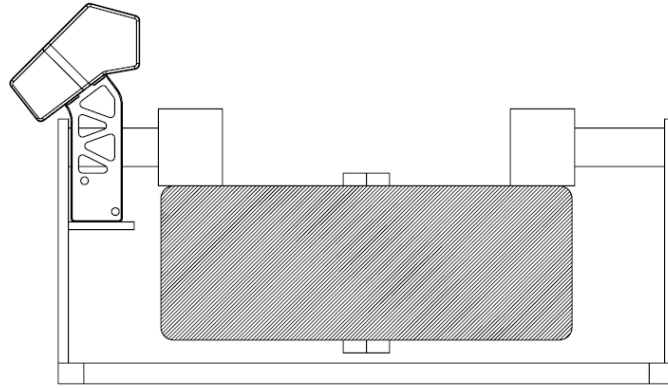

2.2.4 Armor Module

The Armor Module needs to be mounted to the robot via an Armor Module Support Frame.

There are two types of Armor Support Frame: Support Frame A and Support Frame B.

Armor Module Support Frame A is shown in the figure below:

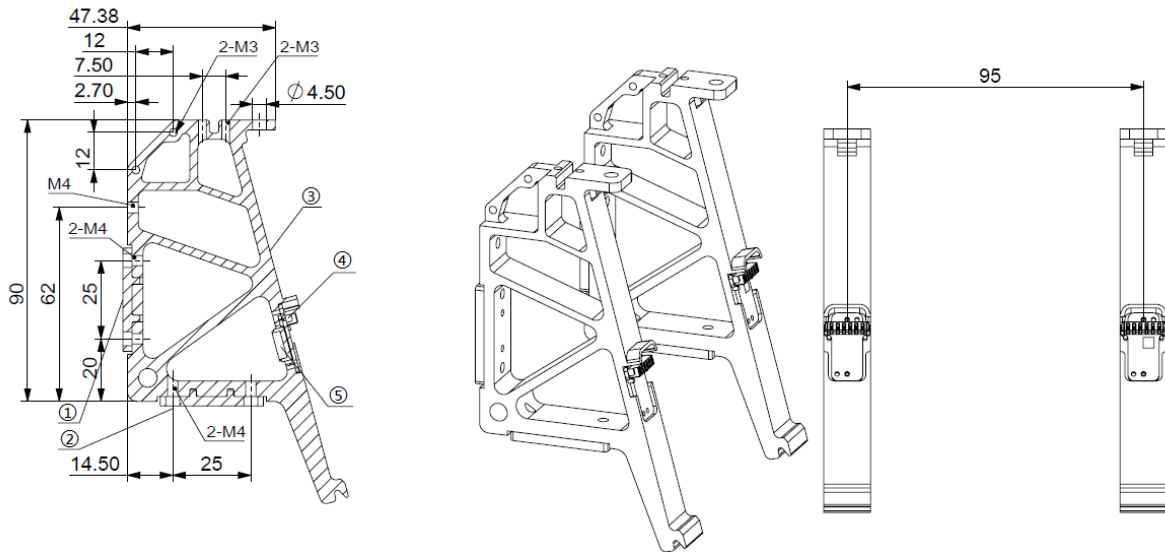

- ① Back Installation Surface
- ② Bottom Installation Surface
- ③ Armor Module Installation Surface
- ④ Electrical Connection Contact Point
- ⑤ JST-6Pin Cable Interface (Front)

Armor Module Support Frame B is shown in the figure below:

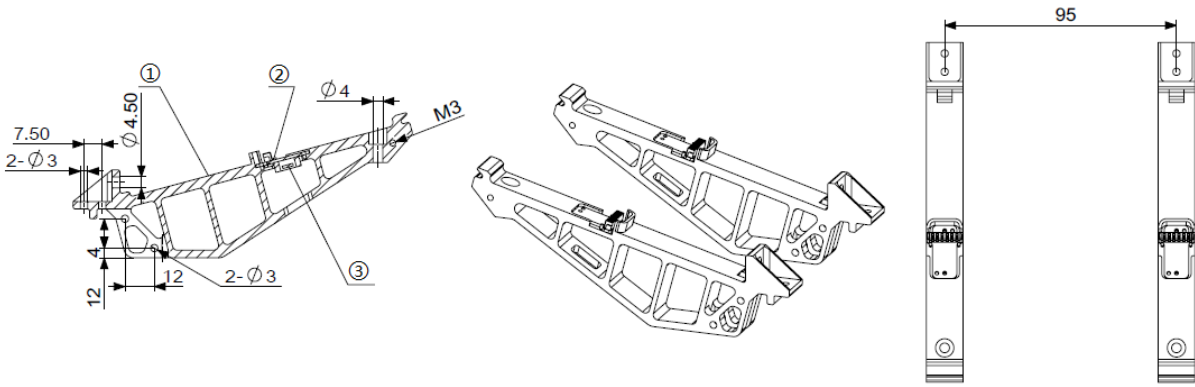

- ① Armor Module Installation Surface
- ② Electrical Connection Contact Point
- ③ JST-6Pin Cable Interface (Rear)

There are two types of Armor Module, Small Armor Module and Large Armor Module. Standard, Hero, Engineer and Sentry require side-mounted Armor Module. In addition, Standard and Hero require an additional top Armor Module. The specific armor type and quantity of each robot are as follows:

Armor Type & Qty.	Small Armor Module	Large Armor Module
Robot Type		
Standard	4	1
Hero	0	5
Engineer	4	0
Sentry	0	2

Small Armor Module is shown in the figure below:

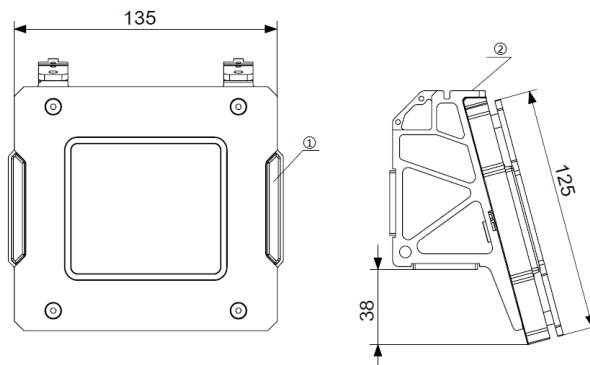

- ① Light Indicator
- ② M4 screw mounting hole on the top of the Armor Support Frame

Large Armor Module is shown in the figure below:

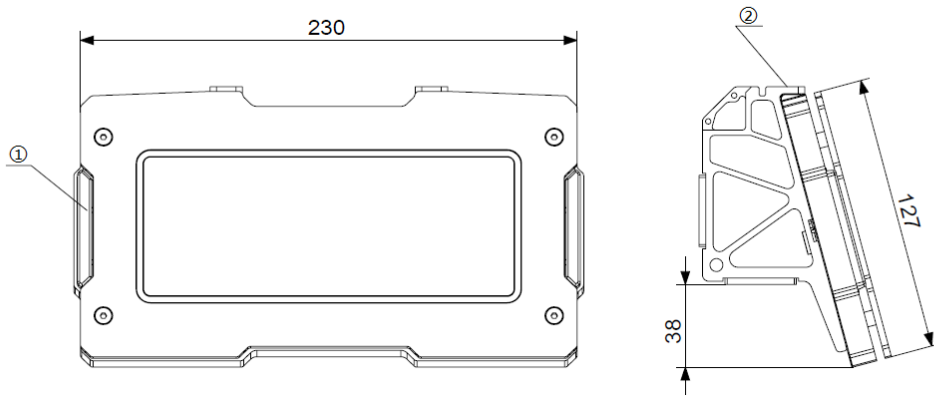

① Light Indicator

② M4 screw mounting hole on the top of the Armor Support Frame

Installation Procedure of Armor Module

Side Armor of Standard, Armor of Engineer and Side Armor of Hero:

Refer to the dimensions shown in the figure below and reserve mounting holes on the chassis. Ensure that the sizes and positions of the four mounting holes are consistent.

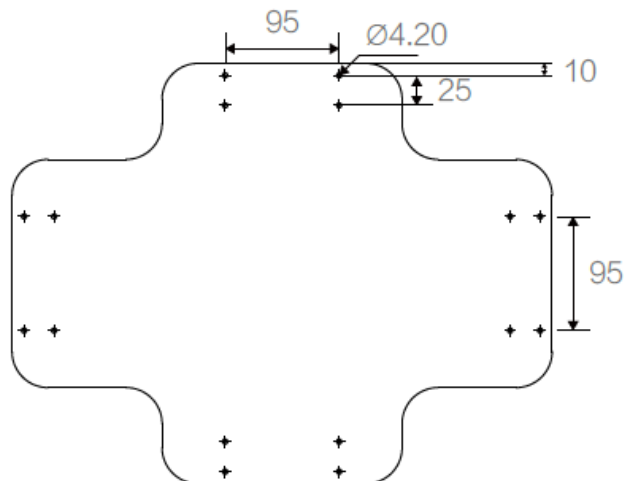

1. Use M4 screws to mount the Support Frame A to the chassis. Each Support Frame A needs to be fixed with two screws.

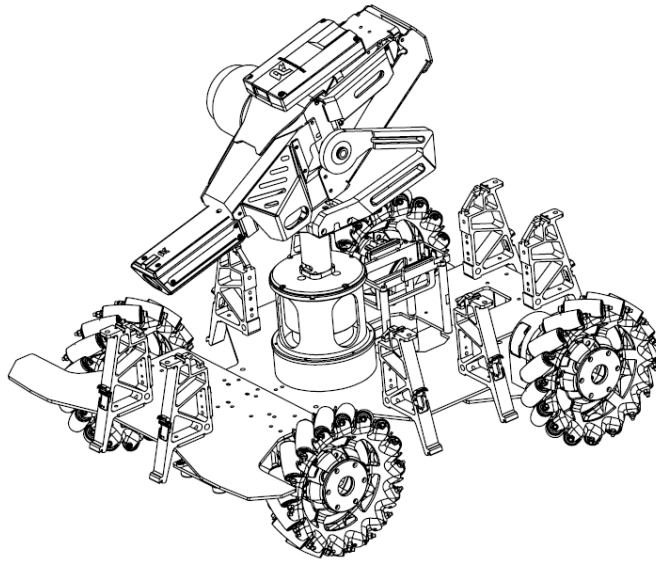

2. Use M4 screws to mount the Armor Module to the Support Frame. When correctly installed, the threaded hole on top of the Armor Support Frame is perpendicular to the horizontal ground, not perpendicular to the top surface of the Support Frame.
3. Use the 6-pin cable provided in the package to connect Armor Modules in series to the Armor Module interface of the Power Management Module. The two 6-pin interfaces of the Armor Support Frame are equivalent interfaces. It is recommended to divide the number of series Armor Modules on the two 6-pin interfaces of the Power Management Module to evenly divide the current of the two interface when connecting.

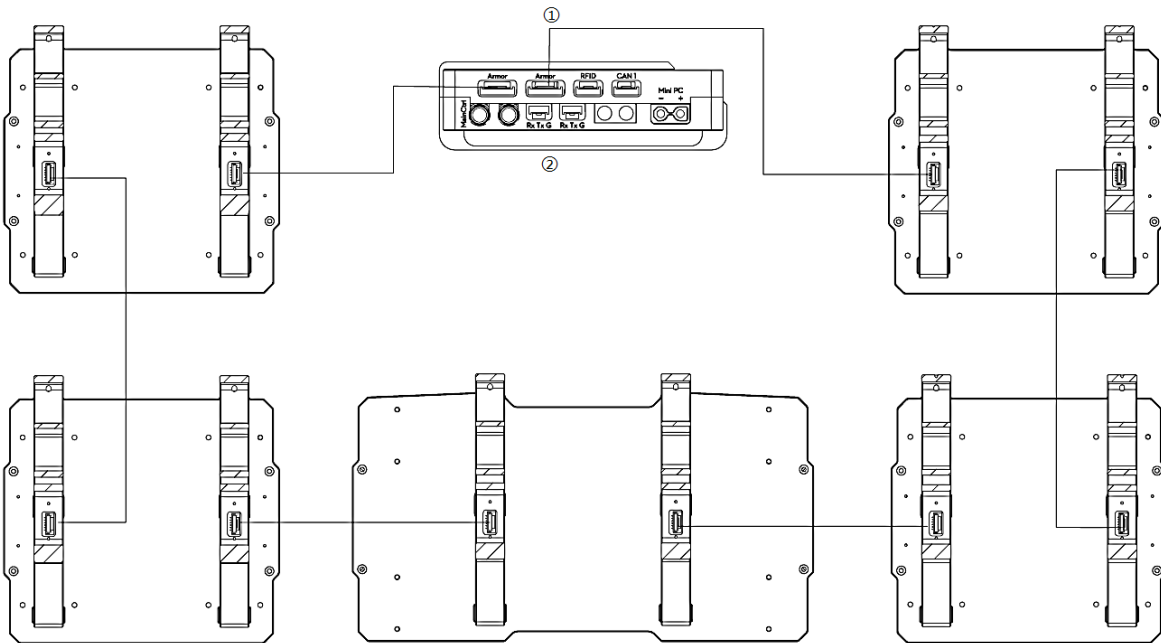

① Power Management Module ② Ratio 2:1

Top Armor of Standard and Top Armor of Hero:

Both Standard and Hero must install a Large Armor Module on the top.

1. Use eight M3 screws to connect the Support Frame A with the Support Frame B and mount the Large Armor onto the Support Frame B.



It is recommended that participants design their own Support Rod to increase the rigid connection between the Top Armor Module and the chassis, reducing the chance of mistaking small projectile as large projectile.

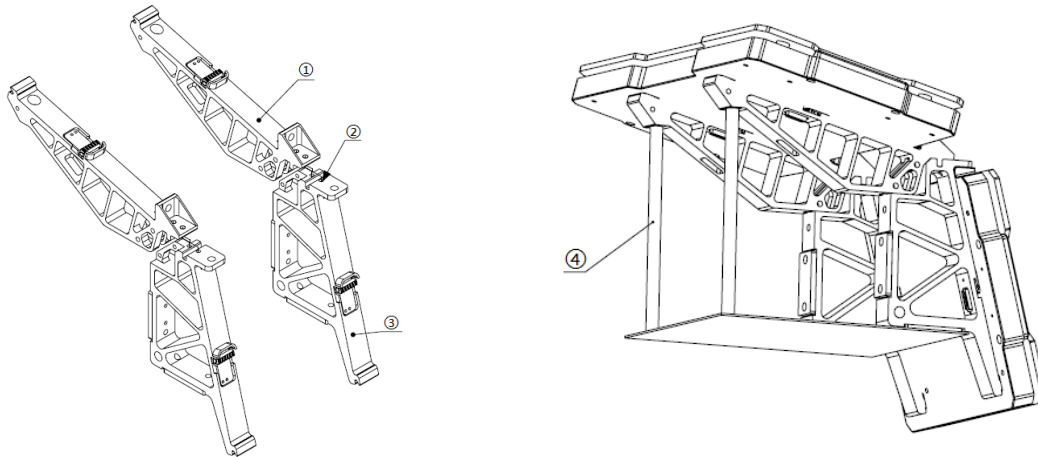

- ① Support Frame B ② M3 Threaded Hole ③ Support Frame A ④ Support Rod

2. The 145° coverage of at least three sides of the Top Armor cannot be blocked, which is the shaded area as shown below. The 145° boundary surface is parallel to the edge line of the armor attack surface. The area that cannot be blocked takes the vertical plane of the edge line of the armor that can be blocked as the boundary surface.

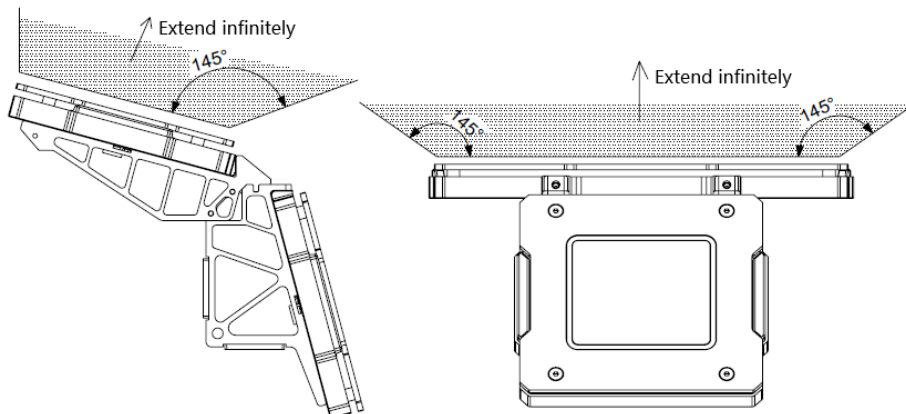

3. Use the 6-pin cable provided in the package to connect Armor Modules in series to the armor module interface of the Power Management Module. The two 6-pin interfaces of the Armor Support Frame are equivalent interfaces. It is recommended to divide the number of series armor modules on the

two 6-pin interfaces of the Power Management Module to evenly divide the current of the two interface when connecting.

Installation Requirement of Armor Module

Side Armor of Standard, Armor of Engineer and Side Armor of Hero:

The lower edge of the attack surface of the Side Armor of Standard and Hero shall not be obscured at angles up to 105° , while the upper, left and right edges of the Armor Module shall not be obscured up to angles of 145° .

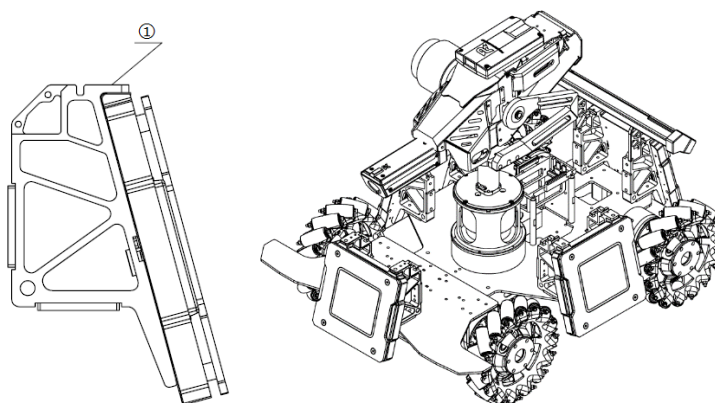

① M4 screw mounting hole on the top of the Armor Support Frame

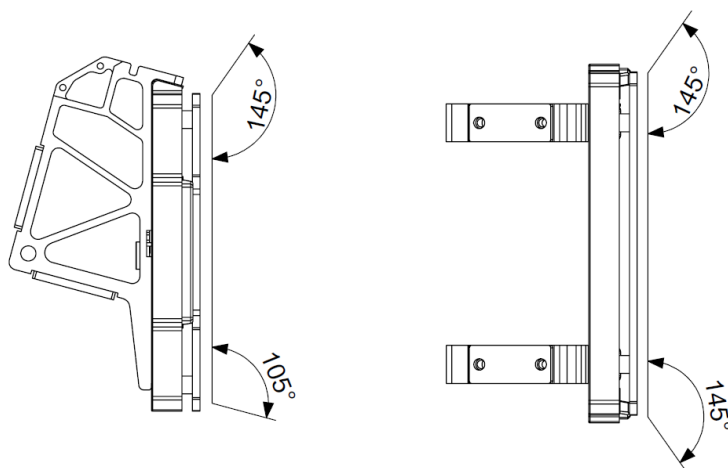

As for Engineer, ensure that the 145° coverage of the attack surface of at least three Side Armor Modules is not blocked, while that of at most one Armor Module is allowed to be restricted to the extent that the scope within 150 mm is not blocked, which is the shaded area shown below.

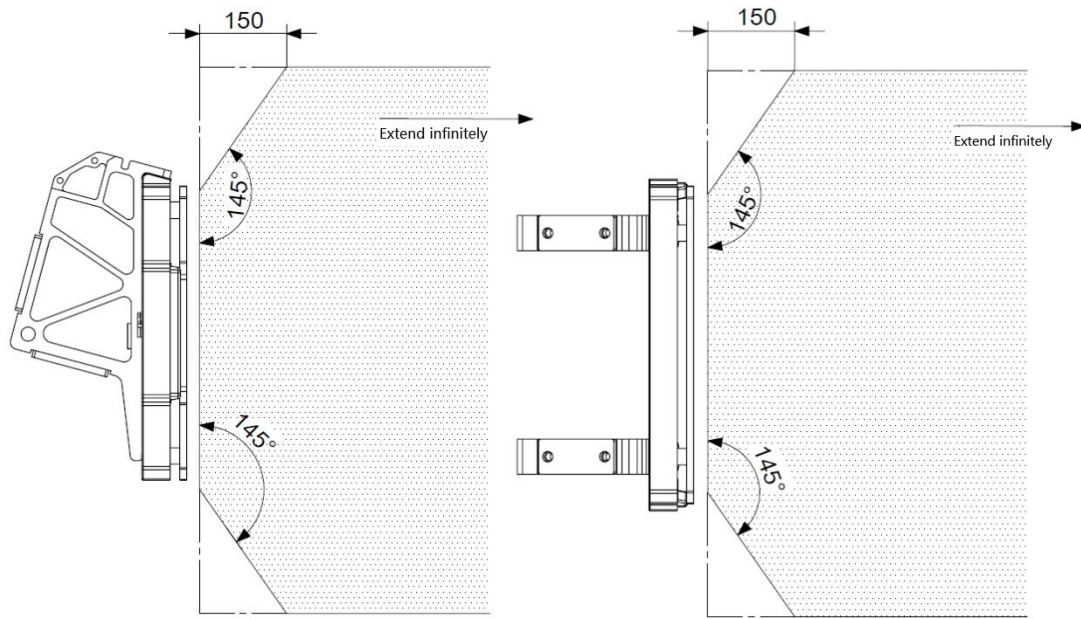

Top Armor of Standard and Top Armor of Hero:

During installation, the Top Armor Support Frame is coupled to the forward Armor Support Frame of the Launching Mechanism, and the Armor attack surface forms an angle of 15° with the horizontal plane. Within the horizontal projection area of the Top Armor attack surface, the horizontal projection area of the mechanism on the Top Armor of Standard cannot exceed 110 * 63 mm or 3500 mm² while that of Hero cannot exceed 120 * 74 mm or 4500 mm².

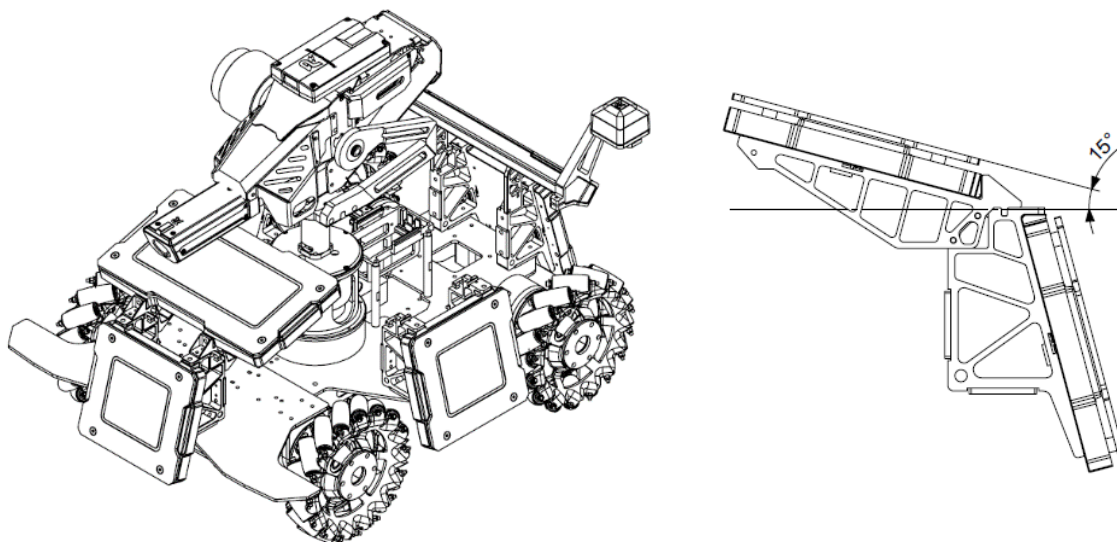

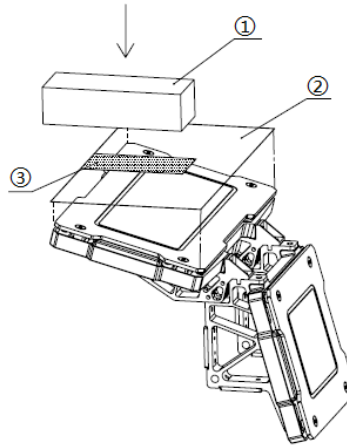

① Robot Mechanism ② Horizontal Plane ③ Robot Mechanism Projection



- The lower edge of the Standard's Side Armor Module must within 60 mm and 150 mm above the ground.
- The lower edge of the Engineer's Side Armor Module must within 60 mm and 400 mm above the ground. The height difference between the lower edge of either Armor Module in the Z-axis direction should not exceed 100 mm.
- The lower edge of the Hero's Side Armor Module must within 60 mm and 200 mm above the ground. The height difference between the lower edge of either Armor Module in the Z-axis direction should not exceed 100 mm.

Sentry:

Refer to the dimensions shown in the figure below and reserve mounting holes on the chassis. Ensure that the sizes and positions of the four mounting holes are consistent.

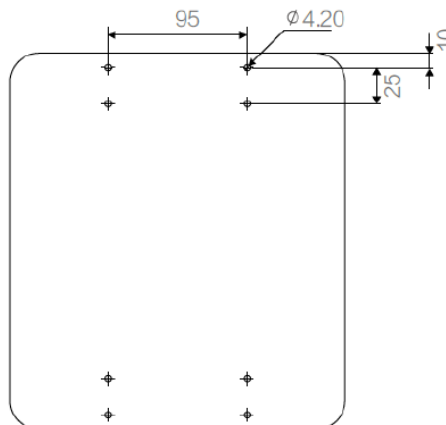

1. Use M4 screws to mount the Support Frame B to the chassis. Note that the threaded hole is on the bottom.

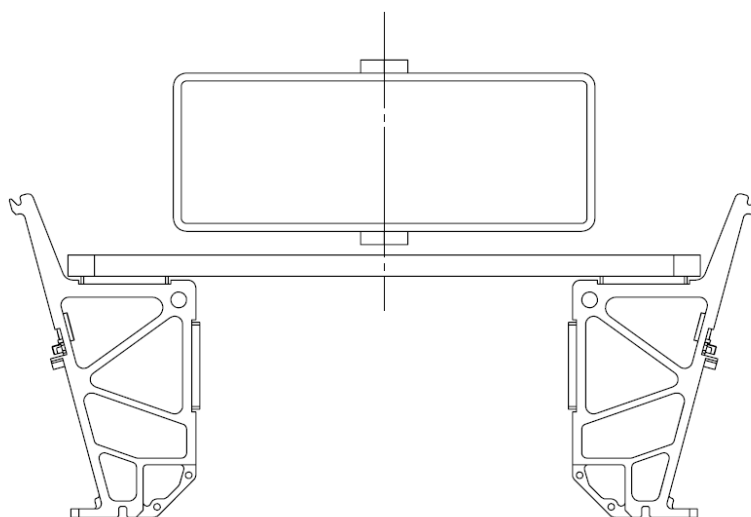

2. Use M4 screws to mount the Large Armor Module to the Support Frame. When correctly installed, the threaded hole on top of the Armor Support Frame is not perpendicular to its bottom surface. Instead, the threaded hole on bottom of the Armor Support Frame is perpendicular to the horizontal ground. The 145° coverage of the attack surface of the Armor Module is not blocked.

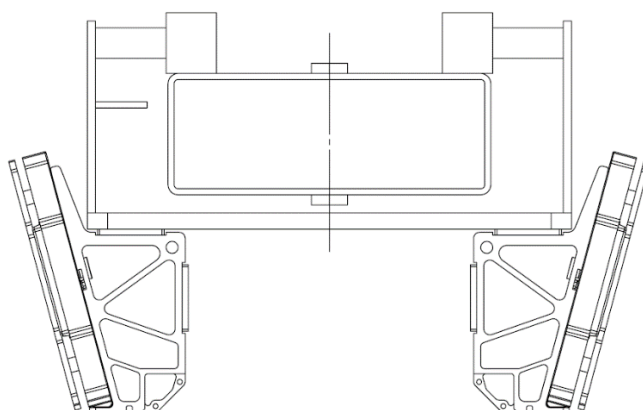

The maximum vertical dimension of Sentry below the upper surface of the Rail should not exceed 450 mm (this dimension limit applies to Sentry at any time). When Sentry is mounted onto the linear section of the Rail, the long side of its Large Armor Module should parallel to the linear section of the Rail; the upper edge of the Armor Module is within the ± 100 mm plane of the upper surface of the Sentry Rail. The attack surface of the Armor Module forms an angle of 75° with the horizontal plane of the Battlefield ground, and the normal line of the Armor Module's attack surface points towards the Battlefield ground.

Installation Specification of Armor Module

In the following section, the robot body coordinate system is a standard XYZ Cartesian coordinate system, with the origin being the robot's center of mass, as shown in the following figure:

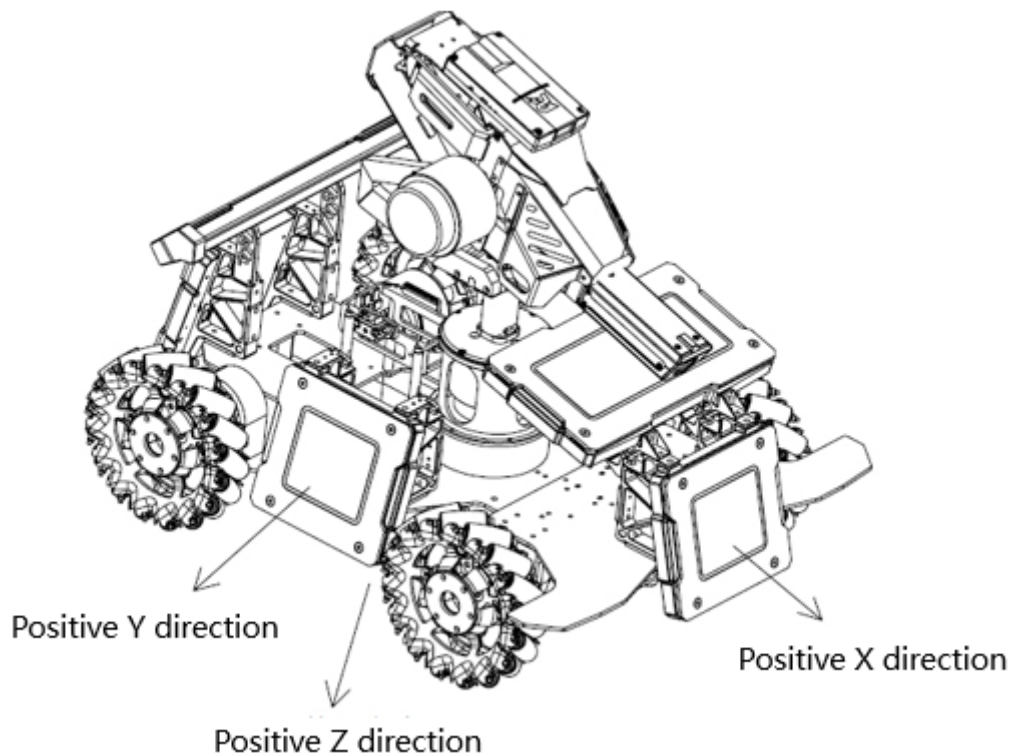

The kinematics equation of the robot should be based on the Cartesian coordinate system. If a team chooses to use a non-Cartesian coordinate system, the robot's coordinate system is defined using the following guidelines: Imagine that the Launching Mechanism of the robot's largest caliber in its initial state launches a projectile. Define the positive X direction as the projected vector on the XY plane of this projectile's projective direction. Establish the positive Y direction by using the positive X direction and the positive Z direction (pointing to the earth's core) according to the right-hand rule, with the robot's center of mass as the origin.

Installation on the Side

When an Armor Module is mounted on the side, its exposure surface must be firmly connected to the Support Frame. Keep the bottom surface of the Armor Support Frame parallel to the XY plane, so that the acute angle between the normal vector of the Armor Module's exposure surface and the negative Z-axis is 75° . Keep the two sides without the indicator light parallel to the XY plane. The Armor Module should be firmly set after the installation. Define the directional vector of any Armor Module as the projected vector of the exposure surface's normal vector (forming an acute angle with the negative Z-axis) on the XY plane. The unit vectors of the direction vectors of the four Armor Modules must be equal to the positive X-axis, negative X-axis, positive Y-axis, and negative Y-axis of the robot's coordinate system respectively. The angular error between the direction vector and the corresponding coordinate vector cannot exceed 5° . The kinematics equations of the robot should also be based on the Cartesian coordinate system in this case. Armor Modules must use the same reference frame as the robot's own structural or kinematic characteristics. The imaginary connection line between the geometric centers of

the Armor Modules mounted on the X-axis should be perpendicular to the counterparts of those mounted on the Y-axis. The two imaginary lines should also pass through the robot's geometric center. Armor Modules mounted on the X- or Y- axis can deviate by ± 50 mm from the geometric center.

Rigid Connection of Armor Module

After the Armor Module is installed, it must be rigidly connected to the chassis. The Armor Module and the chassis must not move relative to each other during the competition. The definition of rigid connection of Armor Module is shown in the figure below. A vertical upward force of 60N is applied to the midpoint of the lower edge of the Armor Module. The change of angle α of the Armor Module's attack surface must not be greater than 2.5° .

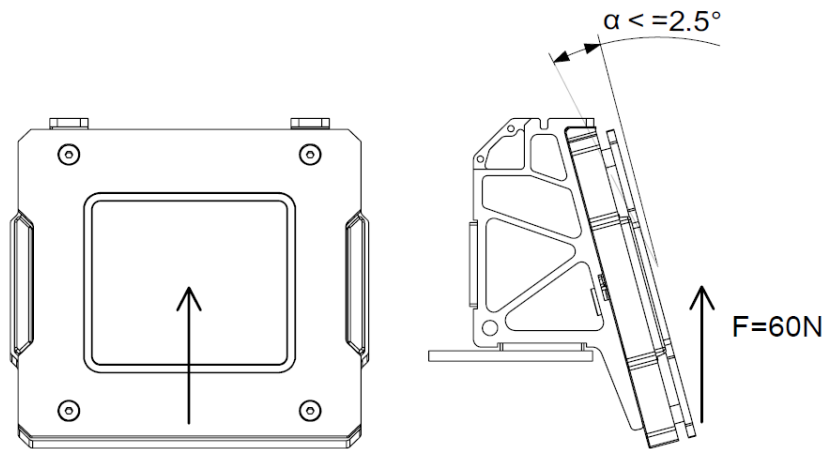

Robot Transformation

In principle, when the competition starts, any Armor Module should not actively move relative to the robot body's center of mass. If a robot is transformable due to its structural design, the requirement for Armor Module is as follows:

- NO Armor Module can move continuously and reciprocally relative to the robot's center of mass as a whole, and the short-term movement speed should not exceed 0.5 m/s.
- For Engineer, the lower edge of the Side Armor Module must within 60 mm and 400 mm above the ground before and after transformation.
- For Hero, the lower edge of the Side Armor Module must within 60 mm and 200 mm above the ground before and after transformation. Besides, the relative position between the geometric center point of the four Side Armor Modules and the horizontal plane of the center axis of the barrel of any horizontal Launching Mechanism cannot be changed during the competition.
- For Sentry, the upper edge of any Armor Module before and after transformation must be ± 100 mm above the plane of the upper surface of the Sentry Rail. The height of the Armor Plate relative to the

Rail plane should not be changed. Horizontal movement relative to the structure used to mount Sentry to the Rail is also not allowed.

Armor Module Protection

It is recommended that the participating teams design bumpers for Standard, Engineer and Hero to reduce the damage caused by the impact of Armor Modules. For the robots with a bumper installed, when facing and closing the vertical rigid plane (wall), the Armor Modules must not make direct contact with the rigid plane (wall), as shown below:

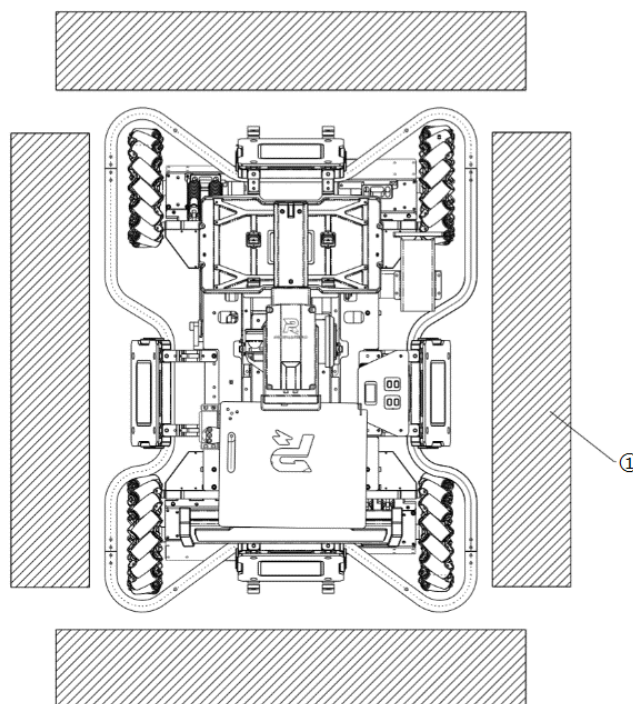

① Wall



- Self-designated protective armor cannot have any contact with the official Armor Module provided by the RoboMaster Organizing Committee.
 - DO NOT change or decorate the official Armor Module provided by the RoboMaster Organizing Committee.
 - Wire the robot reasonably based on its design and ensure that wires are connected securely to prevent damage and wear.
-

2.2.5 Speed Monitor Module

There are two types of Speed Monitor Module: 17 mm Speed Monitor Module and 42 mm Speed Monitor Module.

17 mm Speed Monitor Module:

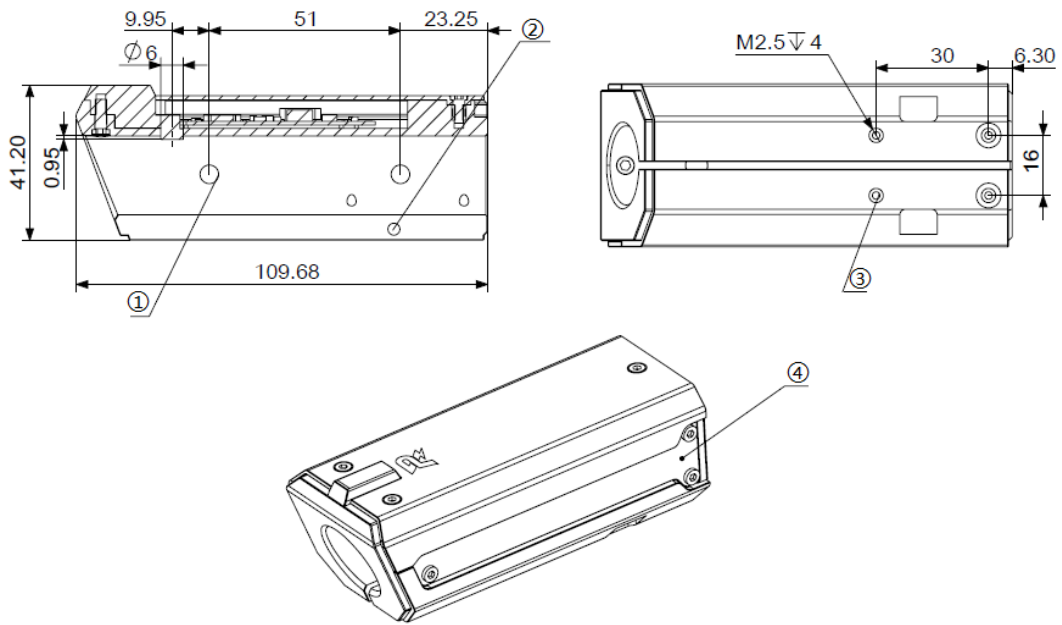

- ① Phototube
- ② Barrel Clamping Screw Hole
- ③ 4-M2.5 Mounting Hole for Laser Sight
- ④ LED Light Bar

Below is the dimension restriction of 17 mm barrel:

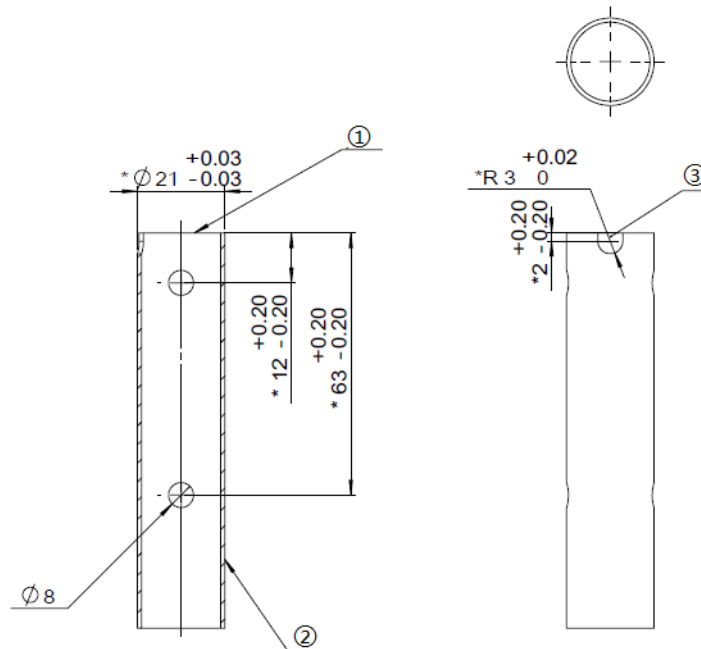

- ① Barrel
- ② * Pipe Wall Thickness must be greater than 1 mm
- ③ The U-shaped groove faces up after the installation of the barrel

- ③ The U-shaped groove faces up after the installation of the barrel

Below is the requirement of 42 mm barrel:

- The barrel length must be greater than 90 mm.
- Pay special attention to the dimension marked with the * sign.
- Ensure that the phototube is not blocked.
- DO NOT use transparent and luminescent material.

Installation Procedure of Speed Monitor Module

17 mm Speed Monitor Module and 42 mm Speed Monitor Module:

1. Place the speed monitor module on the barrel so that the cylindrical step is aligned with the U-shaped groove of the barrel, and the connecting end faces the Main Controller Module.
2. Use M3 screws through the screw holes in the rear of the speed monitor module to clamp the barrel.
3. Connect the speed monitor module to the aviation connector on the main control panel's speed monitor interface. The completed installation is shown in the figure below:

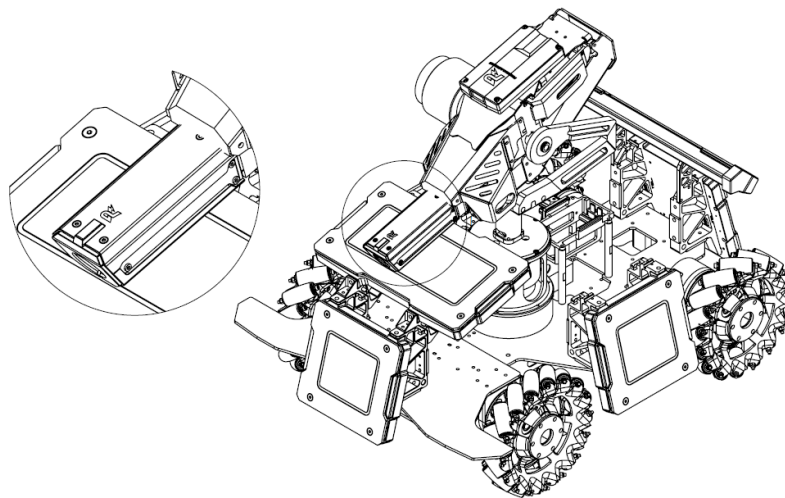

Installation Requirement of Speed Monitor Module

The Speed Monitor Module contains a magnetometer, which is sensitive to electromagnetic environment. Therefore, with the logo at the center, no large magnetic conductive material (devices like iron barrel, cooling fan of VTM Transmitter, friction wheel motor are forbidden in ① as shown below) should be placed within an area measuring 70 mm in diameter.

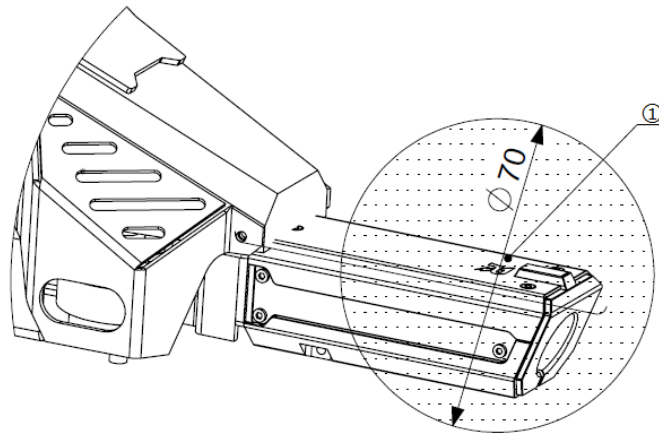

- RM laser sight or self-sustaining laser can be mounted in four M2.5 threaded holes provided.
- DO NOT look at laser directly. It is recommended to wear goggles during operation.
- DO NOT block the mounting holes for the infrared LEDs. Otherwise, the Speed Monitor Module will be unable to initialize.
- The Speed Monitor Module should be firmly secured to avoid relative displacement between the module and the barrel.
- Since the aviation connector cable of the Speed Monitor Module is close to the friction wheel, the cable should be protected from wear when used.
- The 17 mm Speed Monitor Module and 42 mm Speed Monitor Module of Hero can be shielded with each other, while the light bar shielding area on both sides of the Speed Monitor Module of other robots is less than 1/5 of the area of the light bar.

Installation Specification of Speed Monitor Module

In order to improve the shooting accuracy of the participating team robots, on the basis of the original Speed Monitor Module (17 mm projectile) installation specifications, two fixing schemes of 17 mm Speed Monitor Modules have been added, as detailed below.

Including the 17 mm Speed Monitor Module fixing scheme described above, the three fixing schemes are in line with the installation specifications of the Speed Monitor Module (17 mm projectile) used by the Referee System. The participating teams choose one of the fixing schemes.

Newly Added Fixing Scheme 1:

The participating team members design and process the adapter block parts by themselves and connect the 17 mm Speed Monitor Module along with the Launching Mechanism, to replace the fixing scheme of

the long barrel.

The detailed engineering drawings of the adapter block parts are shown in [Appendix 17mm Speed Monitor Module Adapter Block Engineering Drawing](#). The 3D model can be downloaded from the data station of the RoboMaster official website as a reference only.

The adapter block parts are referenced as shown below:

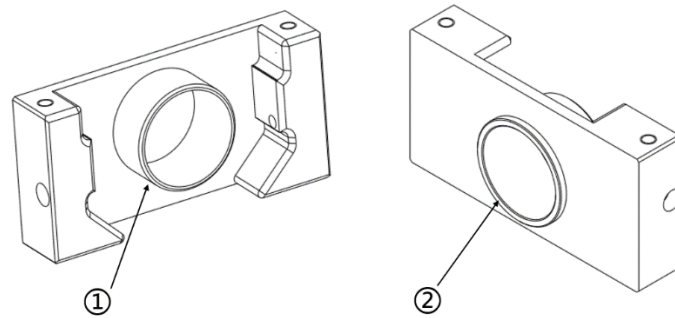

① Front Boss ② Rear Boss

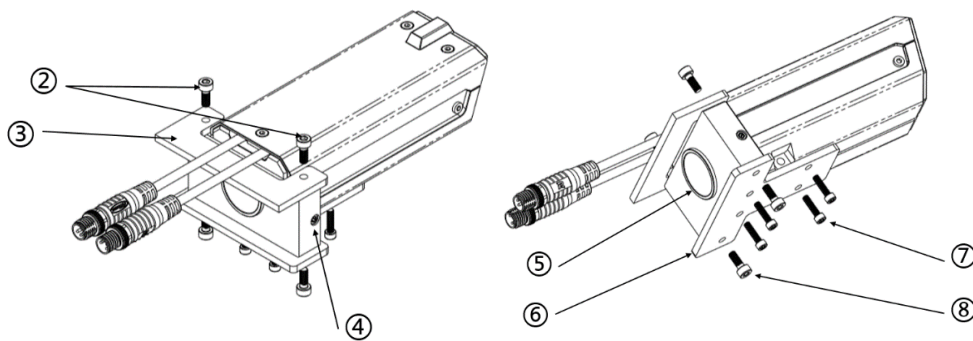
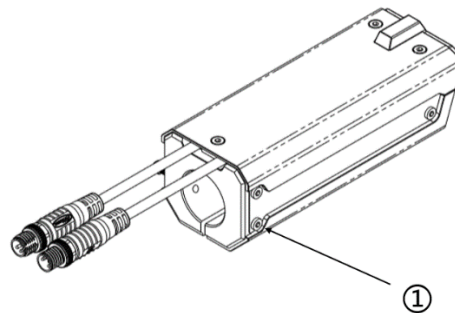

- ① LED Light Bar Fixing Screw M2.5 ② Screw M3 ③ Robot Original Board Part 1 (Homemade)
- ④ Side Fixing Hole ⑤ Rear Boss ⑥ Robot Original Board Part 2 (Homemade)
- ⑦ Screw M2.5 ⑧ Screw M3

Installation Procedure of Newly Added Fixing Scheme 1

1. Remove two LED light bar fixing M2.5 screws on both sides of the Speed Monitor Module. One side of the LED light bar fixing M2.5 screw is shown as ① in the figure.
2. Use two M2.5x14 screws to secure the adapter block to the Speed Monitor Module with the side fixing hole (one side is shown as ④ in the figure).
3. Use two M3 screws to fix the original board part 1 of the robot to the upper end of the Speed Monitor Module.
4. Use two M3 screws and four M2.5 screws to fix the original board part 2 of the robot to the lower end of the Speed Monitor Module.



- The rear boss of the adapter block fits with the original parts of the gimbal to ensure the concentricity of the bullet axis and the axis of the adapter block.
- On the one hand, the front boss of the adapter block ensures the concentricity of the adapter block and the axis of the Speed Monitor Module; while on the other hand, it can absorb a part of the force when the front end of the Speed Monitor Module is impacted.
- Except for the two screws in Step 1 that are allowed to be removed so that the adapter block parts can be fixed with the Speed Monitor Module, the remaining screws on the Speed Monitor Module must not be disassembled and offenders will be regarded as having destroyed the referee system.

Newly Added Fixing Scheme 2:

The participating team members design and process the short barrel parts by themselves and connect the 17 mm Speed Monitor Module and the Launching Mechanism to replace the fixing scheme of the long barrel.

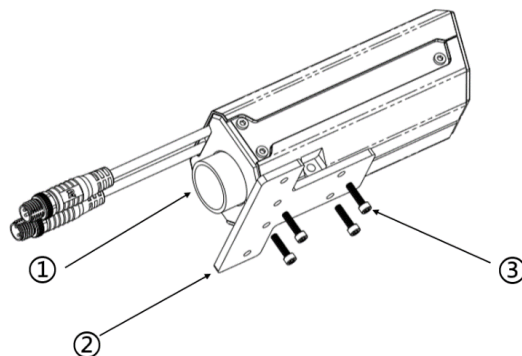

- ① Short Barrel ② Robot Original Board Part 1 (Homemade)
- ③ Screw M2.5

Installation Procedure of Newly Added Fixing Scheme 2

1. Insert the Speed Monitor Module into the short barrel.
2. Use four M2.5 screws to fix the original board part 1 of the robot to the lower end of the Speed Monitor Module.



- The length of the barrel extending into the speed monitor portion shall not be more than 23 mm, so as to avoid blocking the speed monitor photocell of the Speed Monitor Module.
- It is recommended that the outer diameter of the barrel be controlled at $21 \text{ mm} + 0.05$. The small diameter of the barrel will result in a large gap between the outer wall of the barrel and the inner wall of the Speed Monitor Module, meaning alignment of the bullet axis and the axis of the Speed Monitor Module will not be ensured, resulting in an increase in the spread area of the bullet.
- For this scheme, because the Speed Monitor Module and the Launching Mechanism parts are not positioned relative to each other, there is a phenomenon that the axis of the Speed Monitor Module does not align with the axis of the bullet launching, causing some bullets to touch the inner wall of the Speed Monitor Module. When this happens, the participating team members shall adjust the installation angle of the Speed Monitor Module and part B by adding a gasket between B and the Speed Monitor Module, as needed.

2.2.6 RFID Interaction Module

Installation Procedure of Speed Monitor Module

Refer to the structure dimension and installation interface of RFID Interaction Module and reserve mounting holes in the chassis.

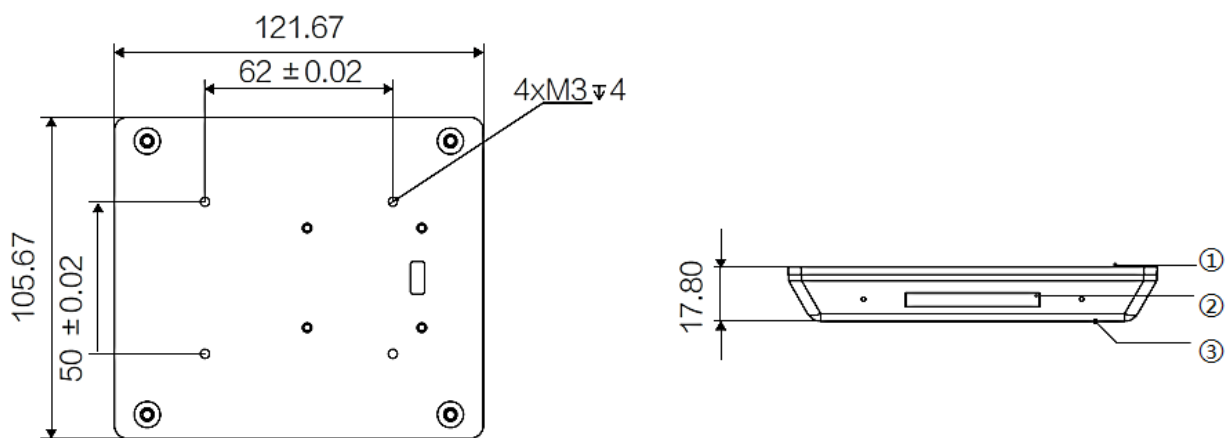

① Rear ② LED Light Bar ③ Front

1. Use the 4-pin cable provided in the package to connect the RFID Interaction Module to the RFID interface on the Power Management Module.

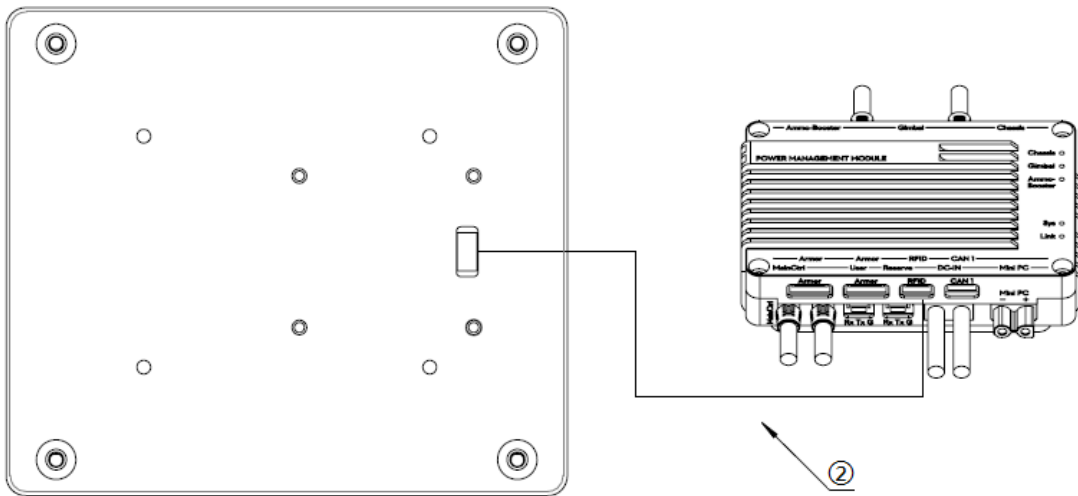

① 4Pin Cable

2. Use M3 screws to mount the RFID Interaction Module to the chassis. DO NOT press or bend the 4-pin cable and maintain a suitable distance from the ground.

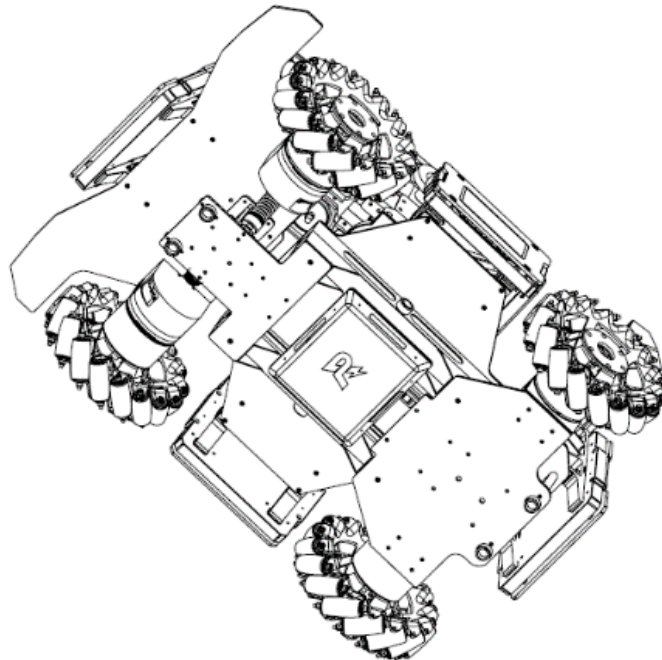

RFID Interaction Module Card

The RFID Interaction Module Card is a function card of the Battlefield Component and is laid in the

corresponding location of the Battlefield. During the competition, the robot will obtain the corresponding gain after detecting the RFID Interaction Module Card through its installed RFID Interaction Module. The dimension of the RFID Interaction Module Card is as follows:

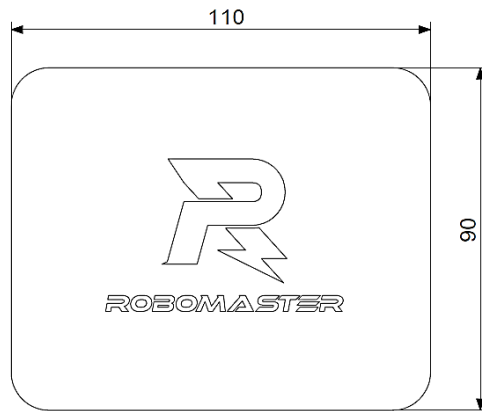

Ensure that the logo side of the RFID Interaction Module is not blocked by any metal object, and that the side without a logo is free of current interference (such as a motor cable or RM center plate). The effective detection distance of the RFID Interaction Module is 100 mm ($\pm 5\%$). The actual detect distance is subject to test. If the distance decreases, check whether the module is installed properly.

2.2.7 Video Transmission Module

Installation Procedure of Video Transmission Module (Transmitter)

Refer to the structure dimension and installation interface of the transmitter and reserve mounting holes in specified positions.

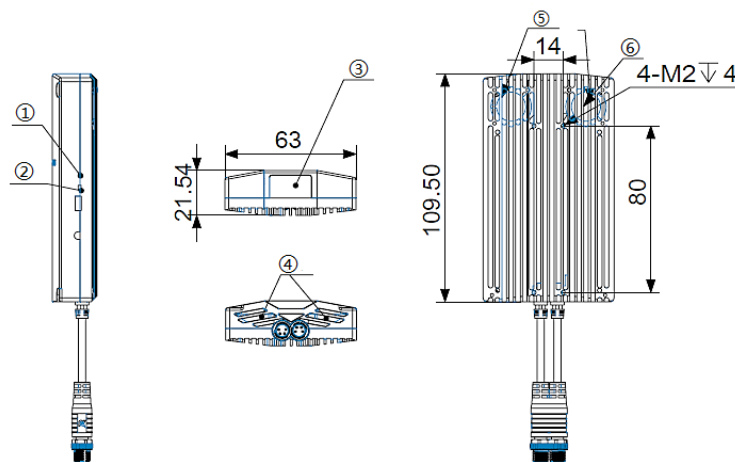

① Video Light Indicator ② Network Light Indicator ③ Camera

④ Air Outlet

⑤ Air Intake

⑥ Cooling Fan

1. Use four M2 screws to mount the Transmitter to the appropriate position. The installation position cannot block the air intake and outlet of the Transmitter. Since the Transmitter antenna is on the top of the module, there must be no metal shield. If fail to install the Transmitter as required will result in abnormal operation.

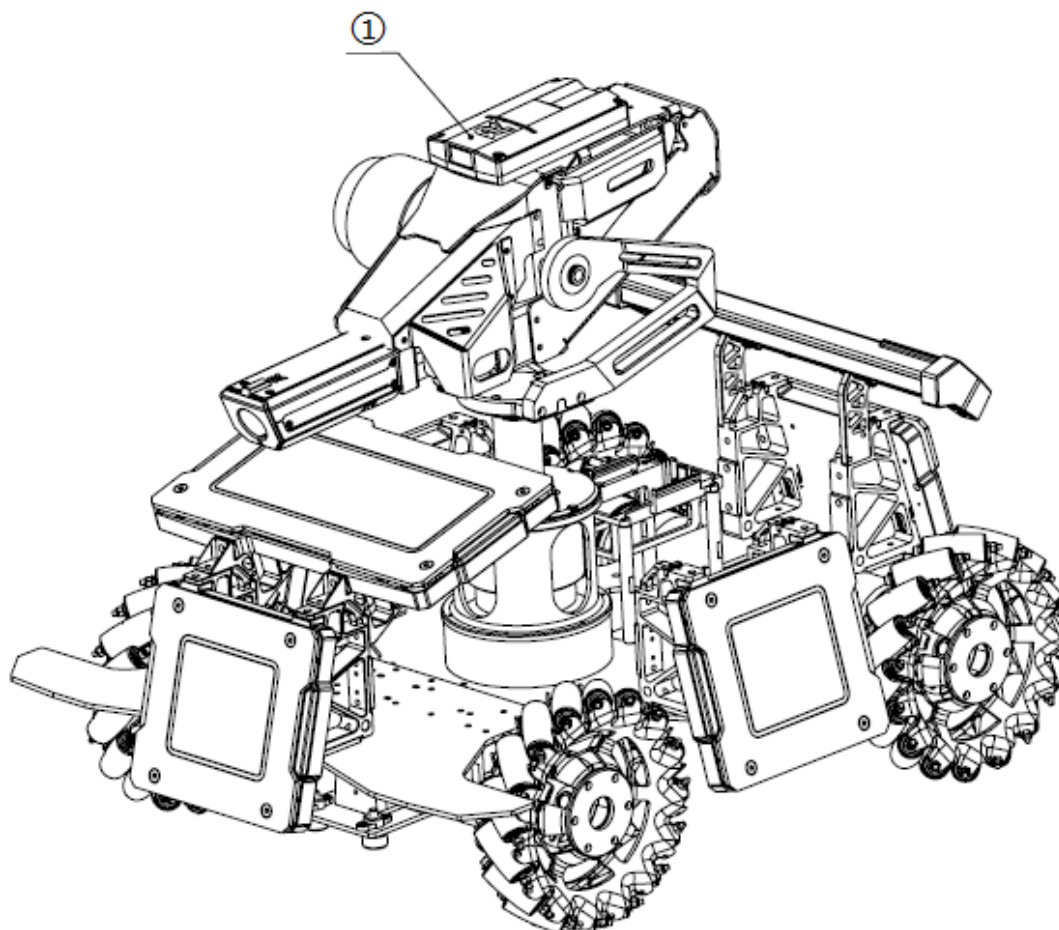

① Video Transmission Module (Transmitter)

2. Connect the aviation connector of the Transmitter to the aviation connector of the VTM interface on the Power Management Module.

Installation Specification of Video Transmission Module (Transmitter)

The VTM receiver can be fixed on a display or other supports with the mounting clip provided. The fix position must be no less than 1 m from the ground with no metal shield.

The specific mounting position can be confirmed through the received image quality.

The VTM Receiver is shown in the figure below:

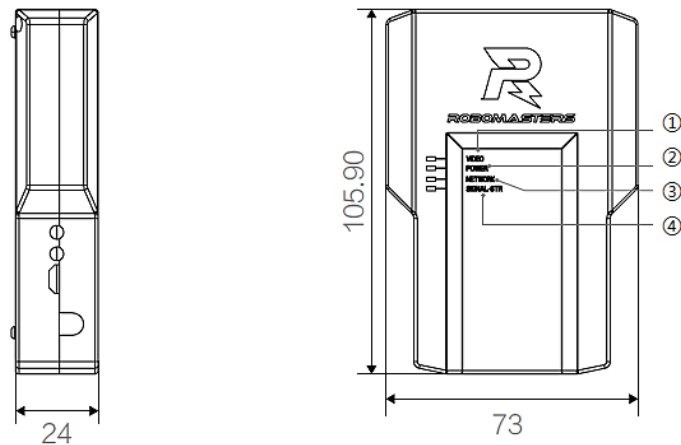

- ① Video Light Indicator ② Power Light Indicator
- ③ Network Light Indicator ④ Signal-STR Light Indicator

2.2.8 Positioning System Module

Installation Procedure of Positioning System Module

Refer to the dimension of the Positioning System Module and reserve mounting holes in specified positions.

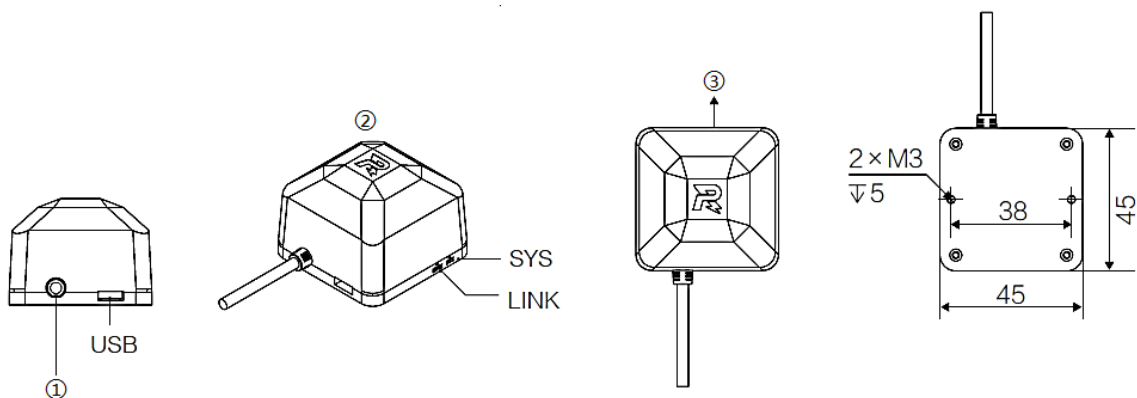

- ① Referee System Cable ② Top ③ Front

1. Use two M3 screws to mount the Positioning System Module to the specified position. The front of the Positioning System Module must be in line with the front of the robot and its top faces up with

horizontal installation. The area within 145° above the Positioning System Module must not be blocked by conductors as shown below:

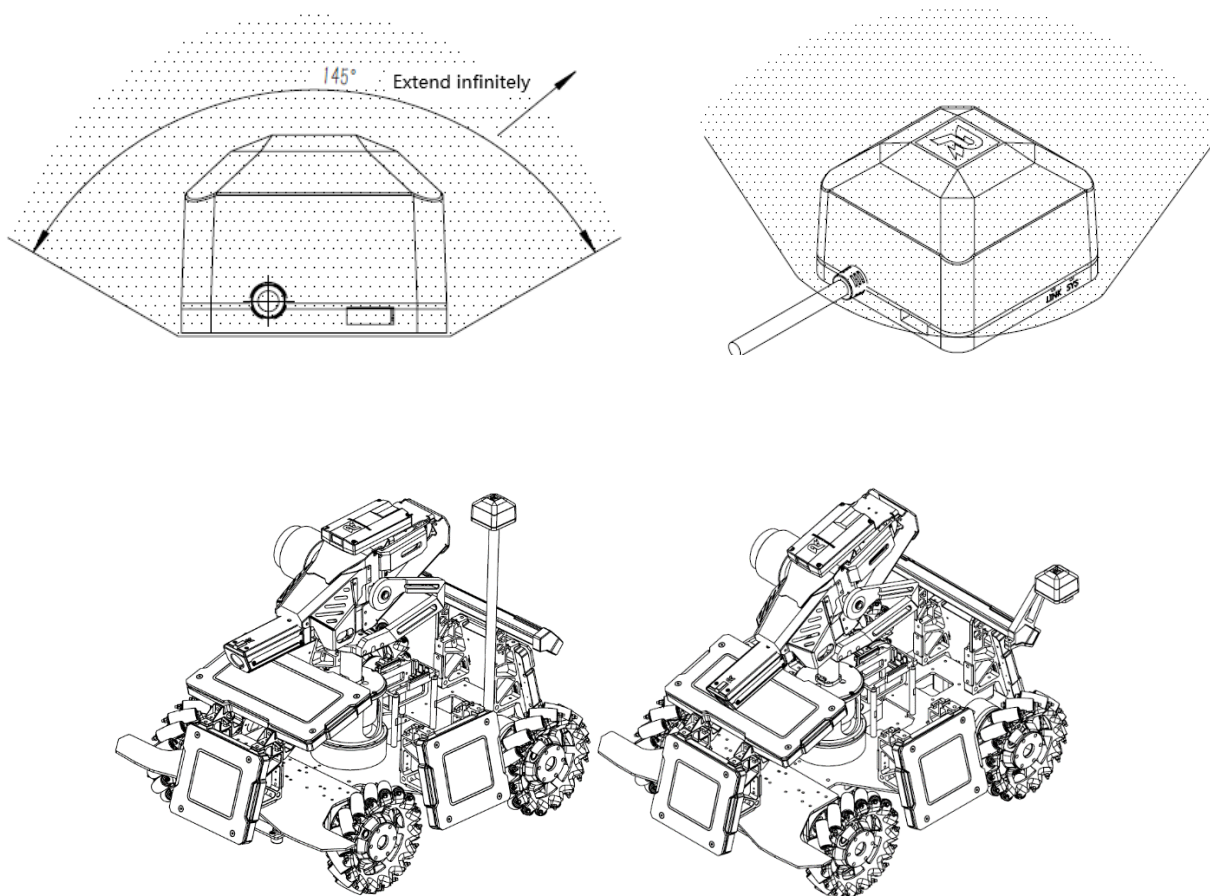

The install requirement of Aerial's Positioning System Module is simplified. At most one side extends horizontally 100 mm can be blocked by conductors.

2. Use the aviation connector cable in the package to connect the Positioning System Module to the aviation connector with the silver metal ring on the Power Management Module.

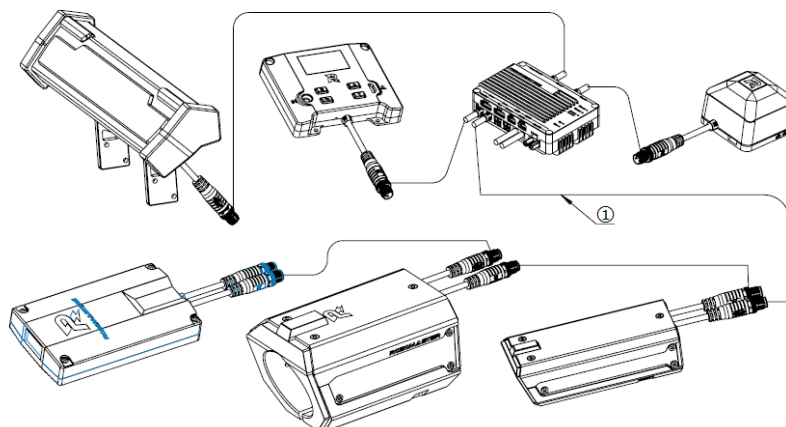

① Aviation Connector Cable



- Aviation connectors of the Light Indicator Module, VTM Transmitter, Speed Monitor Module and Positioning System Module are all equivalent interfaces and can be serially connected to each other.
 - It is recommended to maintain a distance of greater than 20 cm between the installation position of the motor, Video Transmission Module, magnetic component or component that generates strong magnetic fields during operation. The minimum distance should be no less than 10 cm.
 - The Positioning System Module and Support Frame of Sentry is not count toward the overall size constraints.
-

3. Competition Geo-Fence

3.1.1 Purpose

Prevent robots not involved in the competition from connecting with the game system. Otherwise the competition may not proceed normally.

3.1.2 Principle Introduction

Geo-fence uses Battlefield as a boundary. Within the scope of Battlefield is the interior of Geo-fence, the rest is the exterior. A robot can be connected to the competition server only within the geo-fence. Both the Positioning System Module and the Main Controller Module of the Referee System are used to check whether a robot works within the geo-fence.

- Identify the Geo-fence Area with Positioning System Module

According to the description of Positioning System Module in the Module Installation Specification section, the Positioning System Module installed on the robot can calculate the position of the robot relative to the Battlefield by communicating with the Positioning System Module base station installed around the Battlefield. This location information is the basis for accurately judging whether the robot is inside or outside the geo-fence. If it is inside the geo-fence, the Referee System mounted to the robot will automatically connect to the competition server.



The Positioning System Module must be installed in strict accordance with the installation instruction to ensure the accuracy when calculating the location relative to a robot.

- Identify the Geo-fence Area with Main Controller Module

For this function, the infrared receiver on the Main Controller Module can receive the specifically encoded infrared signal and the Main Controller Module will automatically connect to the competition server after receiving the signal. This method can only be used before the competition, within the Three-minute Setup Period or within the 20-second Referee System Initialization Period before the start of the competition. During the period, if the robot in the Battlefield cannot connect to the competition server, the staff will use a custom remote controller to solve this problem. The following chart shows how the Referee System uses the geo-fence to connect to the competition server:

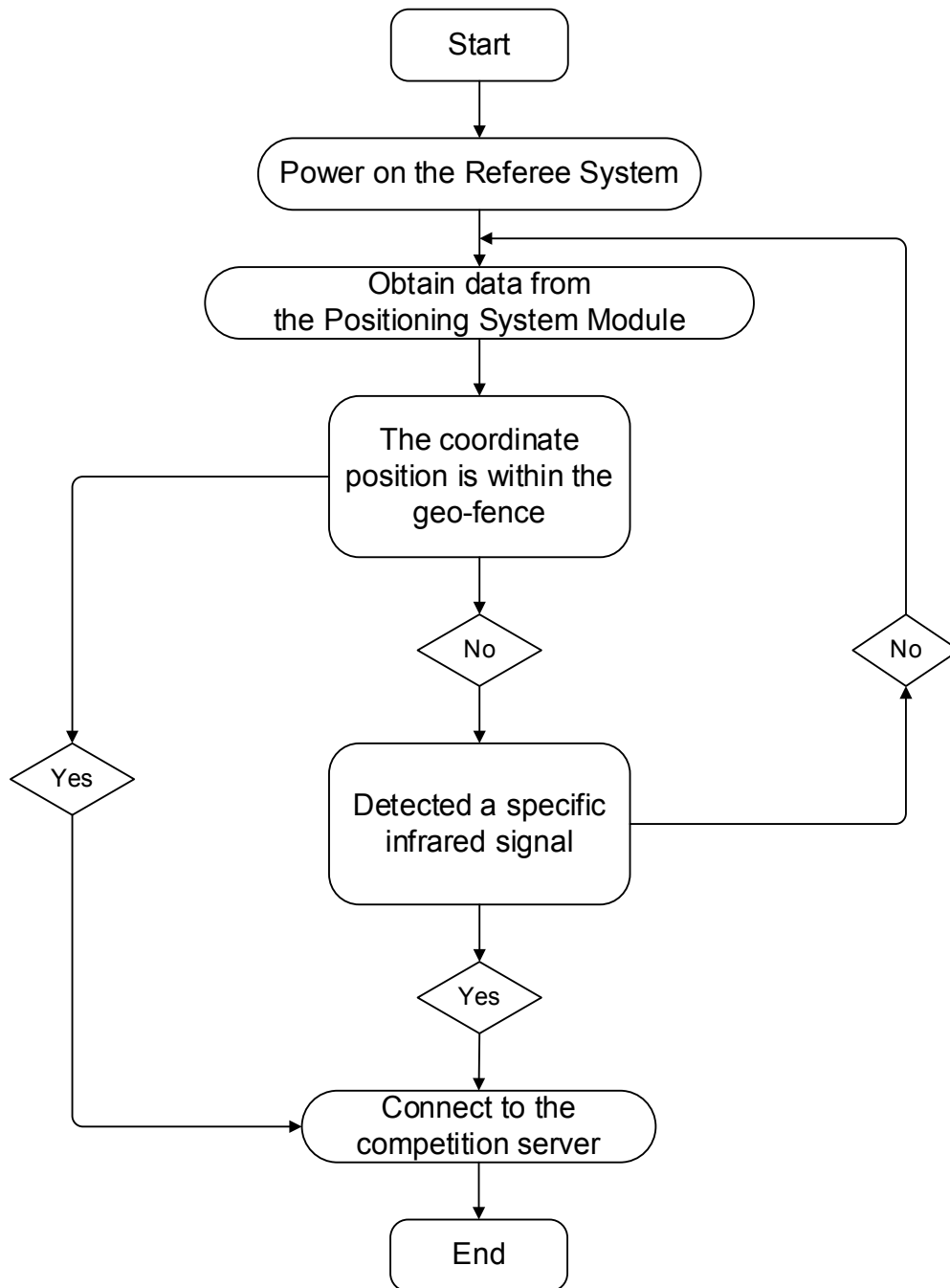

The geo-fence relies on the Positioning System Module. If the Positioning System Module is installed correctly, during the competition, when the robot unexpectedly loses power and restarts, the robot can re-connect to the competition system within 20 seconds to continue the match. Otherwise, the Positioning System Module cannot generate the correct locating information within 20 seconds, which causes the robot to be unable to connect to the competition system and the server will immediately deduct the remaining HP of the robot.

Appendix 17mm Speed Monitor Module Adapter Block Engineering Drawing

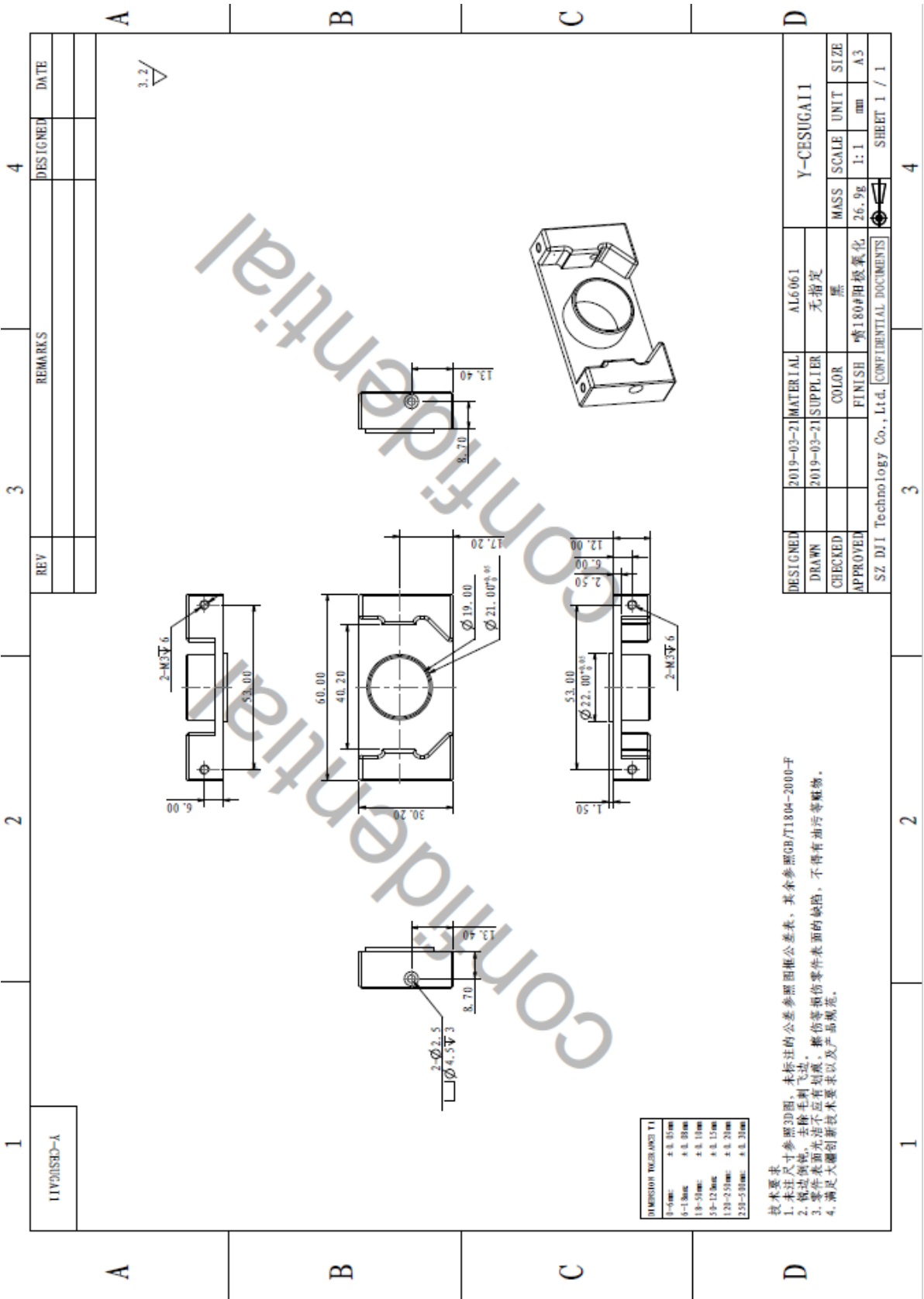



E-mail: robomaster@dji.com

Forum: bbs.robomaster.com

Website: www.robomaster.com

Tel: +86 (0)755 36383255 (GTC+8, 10:00AM-7:00PM, Monday to Friday)

Address: Room 202, Floor 2, Integrated Circuit Design & Application Industrial Park, No. 1089,
Chaguang Road, Xili County, Nanshan District, Shenzhen City, Guangdong Province, China